

# JVC



ENGLISH

中文

한국어

ไทย

DVD/CD RECEIVER  
收音組合機 DVD/CD  
DVD/CD 수신기  
เครื่องเล่น DVD/CD

## KD-DV5000

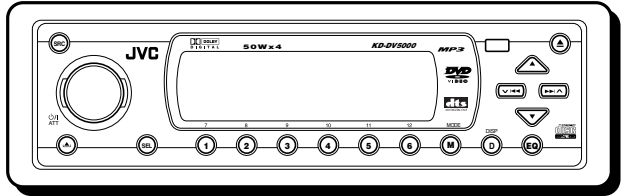
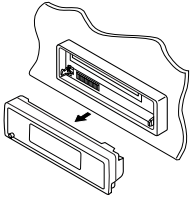

This unit is equipped with the display demonstration. To cancel it, see page 9.

對本機具有顯示演示功能。要取消該功能，請參閱第9頁。

이 장치에는 디스플레이 데모 기능이 있습니다. 기능을 취소하려면9 페이지를 참조하십시오.

เครื่องนี้ได้รับการติดตั้งการสาธิตภาพประกอบ หากต้องการยกเลิก โปรดดู หน้า 9

For installation and connections, refer to the separate manual.

有關安裝和連接方法，分別參閱操作手冊。

설치 및 연결을 하실 때에는 별도의 장착 매뉴얼을 참조하여 주십시오.

กรุณาดูคู่มือที่แยกต่างหาก ในการติดตั้งและการเชื่อมต่อ

# INSTRUCTIONS

## 使用說明書

## 사용설명서

## คำแนะนำ

## Position And Reproduction Of Labels

Bottom panel of the main unit

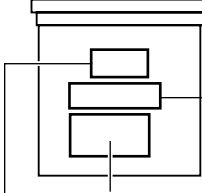

Name/Rating plate

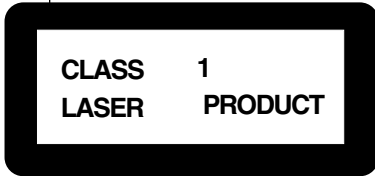

**Caution:**

This product contains a laser component of higher laser class than Class 1.

<b>CAUTION:</b> Invisible laser radiation when open and interlock failed or defeated. <b>AVOID DIRECT EXPOSURE TO BEAM.</b>	<b>ADVARSEL:</b> Usynlig laserstråling ved åbning, når sikkerhedsafbrydere er ude af funktion. Undgåudsættelse for stråling. (e)	<b>WARNING:</b> Osynlig laserstråling när denna del är öppnad och spärren är urkopplad. Betrakta ej strålen. (d)	<b>VARO:</b> Avattaessa ja suojalukitus ohitettaessa olet alltiina näkymättömälle lasersäteilylle. Älä katso säteeseen. (f)
---	--	--	---

### IMPORTANT FOR LASER PRODUCTS

**Precautions:**

1. CLASS 1 LASER PRODUCT
2. **CAUTION:** Invisible laser radiation when open and interlock failed or defeated. Avoid direct exposure to beam.
3. **CAUTION:** Do not open the top cover. There are no user-serviceable parts inside. Leave all servicing to qualified service personnel.
4. **CAUTION:** This DVD/CD player uses invisible laser radiation and is equipped with safety switches to prevent radiation emission when unloading discs. It is dangerous to defeat the safety switches.
5. **CAUTION:** Use of controls, adjustments or performance of procedures other than those specified herein may result in hazardous radiation exposure.

### How to reset your unit

After detaching the control panel, press the reset button on the panel holder using a ball-point pen or similar tool. This will reset the built-in microcomputer.

**NOTE:**

*If you reset the unit during play, the playback mode selections (e.g. repeat play mode setting), you have selected for the current disc will be reset to the initial settings.*

- *During DVD playback, the disc menu selection will also be reset to the initial disc settings.*

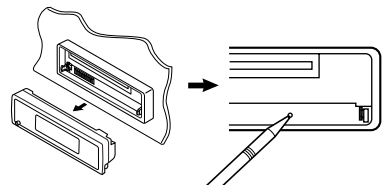

Thank you for purchasing a JVC product. Please read all instructions carefully before operation, to ensure your complete understanding and to obtain the best possible performance from the unit.

## WARNINGS

- **DO NOT** install any unit in locations where;
  - it may obstruct the steering wheel and gearshift lever operations, as this may result in a traffic accident.
  - it may obstruct the operation of safety devices such as air bags, as this may result in a fatal accident.
  - it may obstruct visibility.
- **DO NOT** operate any unit while manipulating the steering wheel, as this may result in a traffic accident.
- **The driver must not watch the monitor while driving.**  
If the driver watches the monitor while driving, it may lead to carelessness and cause an accident.
- **The driver must not put on the headphones while driving.** It is dangerous to shut off the outside sounds while driving.
- If you need to operate the unit while driving, be sure to look ahead carefully or you may be involved in a traffic accident.
- **If the parking brake is not engaged, “DRIVER MUST NOT WATCH THE MONITOR WHILE DRIVING.” appears on the monitor, and no playback picture will be shown.**
  - This warning appears only when the parking brake wire is connected to the parking brake system built in the car (refer to the Installation/Connection Manual).

**CAUTION: DO NOT** insert a disc while the disc loading lamp is flashing or is not lit. (See page 18.)

This product incorporates copyright protection technology that is protected by method claims of certain U.S. patents and other intellectual property rights owned by Macrovision Corporation and other rights owners. Use of this copyright protection technology must be authorized by Macrovision Corporation, and is intended for home and other limited viewing use only unless otherwise authorized by Macrovision Corporation. Reverse engineering or disassembly is prohibited.

### **CAUTION on Volume Setting:**

*Discs produce very little noise compared with other sources. If the volume level is adjusted for the tuner, for example, the speakers may be damaged by the sudden increase in the output level. Therefore, lower the volume before playing a disc and adjust it as required during playback.*

### **Caution:**

*If the temperature inside the car is below 0°C, the movement of animation and text scroll will be halted on the display to prevent the display from being blurred.  (LOW TEMP.) indicator appears on the display.*

*When the temperature increases, and the operating temperature is resumed, these functions will start working again.*

## BEFORE USE

### **\* For safety...**

- Do not raise the volume level too much, as this will block outside sounds, making driving dangerous.
- Stop the car before performing any complicated operations.

### **\* Temperature inside the car...**

*If you have parked the car for a long time in hot or cold weather, wait until the temperature in the car becomes normal before operating the unit.*

# CONTENTS

How to reset your unit .....	2	<b>DVD SETUP MENU .....</b>	<b>43</b>
<b>LOCATION OF THE BUTTONS .....</b>	<b>5</b>	Basic setting procedure .....	43
Control panel .....	5	<b>SOUND ADJUSTMENTS .....</b>	<b>47</b>
Remote controller .....	6	Adjusting the sound .....	47
Preparing the remote controller .....	7	Selecting preset sound modes (iEQ: intelligent equalizer) .....	48
<b>BASIC OPERATIONS .....</b>	<b>8</b>	Storing your own sound adjustments .....	49
Turning on the power .....	8	<b>OTHER MAIN FUNCTIONS .....</b>	<b>50</b>
Canceling the display demonstration .....	9	Changing the general settings (PSM) .....	50
Setting the clock .....	9	Selecting the dimmer mode .....	54
Activating the level meter .....	10	Changing the display color .....	55
<b>RADIO OPERATIONS .....</b>	<b>11</b>	Assigning names to the sources .....	57
Listening to the radio .....	11	Detaching the control panel .....	58
Storing stations in memory .....	13	<b>CD CHANGER OPERATIONS .....</b>	<b>59</b>
Tuning in to a preset station .....	14	Playing discs .....	59
Changing the display pattern .....	15	Selecting the playback modes .....	63
<b>PLAYABLE DISCS .....</b>	<b>16</b>	<b>EXTERNAL COMPONENT OPERATIONS ....</b>	<b>65</b>
<b>BASIC DISC PLAYBACK .....</b>	<b>18</b>	Playing an external component .....	65
Starting playback .....	18	<b>ADDITIONAL INFORMATION .....</b>	<b>66</b>
Locating a particular title/chapter/track .....	20	<b>LANGUAGE CODES .....</b>	<b>67</b>
Locating a particular folder .....	21	<b>GLOSSARY .....</b>	<b>68</b>
<b>DVD/VCD SPECIAL FUNCTIONS .....</b>	<b>22</b>	<b>TROUBLESHOOTING .....</b>	<b>69</b>
Selecting subtitles .....	22	<b>MAINTENANCE .....</b>	<b>72</b>
Selecting audio languages .....	23	Handling discs .....	72
Selecting multi-angle views .....	23	<b>SPECIFICATIONS .....</b>	<b>73</b>
Menu operations .....	24		
Zoom in .....	25		
<b>ADVANCED DISC OPERATIONS .....</b>	<b>26</b>		
Searching for a particular point .....	26		
Playing in various play modes .....	28		
<b>DUAL ZONE OPERATIONS .....</b>	<b>30</b>		
Listening with headphones .....	30		
<b>OSD DISC OPERATIONS .....</b>	<b>32</b>		
Operations on the monitor screen .....	32		
<b>OTHER DISC OPERATIONS .....</b>	<b>35</b>		
Basic disc playback .....	35		
Locating a title/chapter/track on a disc .....	36		
Selecting a folder/track to play using the lists .....	37		
Selecting playback modes .....	38		
Prohibiting disc ejection .....	41		
Changing the display pattern .....	41		



## Control panel

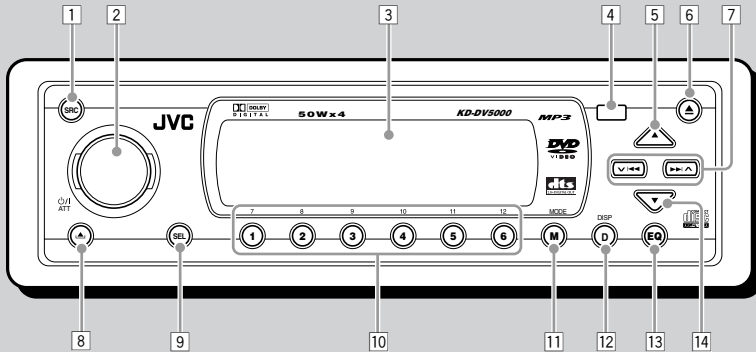

Refer to the pages in parentheses for details.

- |  |  |
|--|--|
| <p>1 SRC (source) button (8, 57, 59, 65)</p> <p>2 <b>•</b> <b>⏻</b> <b>/</b> <b>ATT</b> (standby/on/attenuator) button (8)</p> <ul style="list-style-type: none"> <li>• Control dial</li> </ul> <p>3 Display window</p> <p>4 Remote sensor</p> <p>5 <b>▲</b> (up) button</p> <ul style="list-style-type: none"> <li>• Functions as the Play button for DVDs and VCDs.</li> </ul> | <p>6 <b>▲</b> (eject) button (20, 35)</p> <p>7 <b>▼</b> <b>⏮</b> <b>⏪</b> <b>⏩</b> <b>⏭</b> buttons</p> <p>8 <b>⏏</b> (control panel release) button (58)</p> <p>9 SEL (select) button</p> <p>10 Number buttons</p> <p>11 MODE (M) button</p> <p>12 DISP (D) (display) button (10, 15, 41, 60, 65)</p> <p>13 EQ (equalizer) button (10, 48)</p> <p>14 <b>▼</b> (down) button</p> <ul style="list-style-type: none"> <li>• Functions as the Stop button for DVDs and VCDs.</li> </ul> |
|--|--|

### How to use the MODE (M) button

If you press MODE (M), the unit goes into functions mode. While in functions mode, the number buttons work as different function buttons.

- The **▲**/**▼** buttons also work as **+10**/**-10** buttons after pressing MODE (M).

Ex.: When the source is the tuner

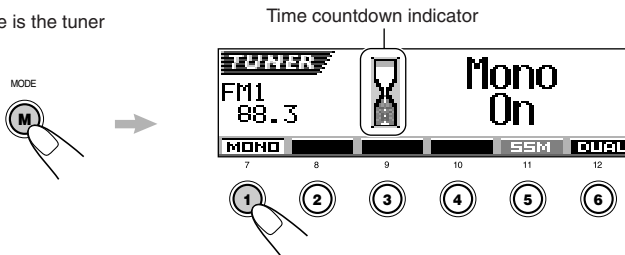

To use these buttons for original functions again after pressing MODE (M), wait for 5 seconds without pressing any of these buttons until the functions mode is cleared.

- Pressing MODE (M) again also clears the functions mode.

# Remote controller

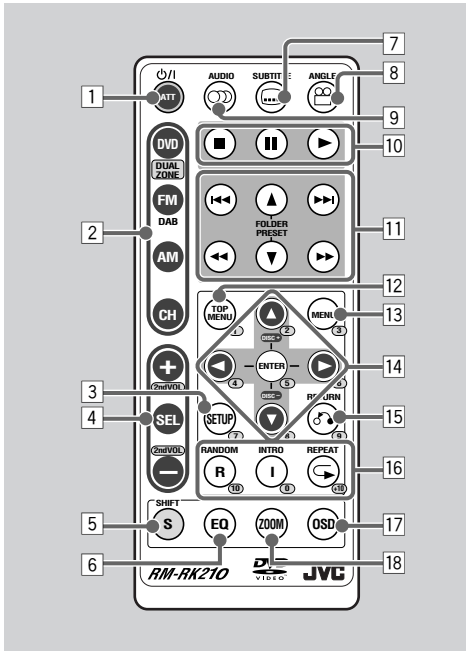

**IMPORTANT:**  
If "Dual Zone" is turned on (see page 30), the remote controller only functions for operating the DVD/CD player.

Refer to the pages in parentheses for details.

- 1 **⏻/⏻ ATT** (standby/on/attenuator) button
- 2 **Source selection** button  
DVD, FM, AM, and CH
  - DVD button also functions as the DUAL ZONE button while pressed with SHIFT (S) button. (30)
  - FM button also functions to change the FM bands. Each time you press the button, FM band changes to FM1, FM2, and FM3 in sequence.
  - FM button does not function as the DAB button for this model.
  - CH button does not function if no CD changer is connected.

- 3 **\*SETUP** button (43)
- 4 **Basic sound setting** buttons  
SEL, +, and -
  - The +/- buttons normally function as the volume adjustment buttons.
  - The +/- buttons also function as the 2ndVOL +/- buttons when pressed with SHIFT (S) button. (31)
- 5 **SHIFT (S)** button
- 6 **EQ (equalizer)** button (48)
  - This button does not work for selecting the level meter.
- 7 **SUBTITLE** button (22)
- 8 **ANGLE** button (23)
- 9 **AUDIO** button (23)
- 10 **Disc basic operation** buttons (20)
  - (stop), (pause), (play)
- 11 **Disc advanced operation** buttons  
 / (reverse search/forward search)
  - The / buttons also work for searching for stations.
  - / (reverse/fast forward)
  - These buttons do not work for CD changer operations.
- FOLDER PRESET** /
  - The FOLDER PRESET / buttons also work for selecting the preset stations.
- 12 **\*TOP MENU** button (24)
- 13 **\*MENU** button (24)
- 14 **\*Menu operation** buttons  
Cursor ( / / / ), and ENTER
- 15 **\*RETURN** button (24)
- 16 **\*Play mode** buttons (28, 29, 63, 64)  
RANDOM (R), INTRO (I), and REPEAT ()
- 17 **OSD** button (32)
- 18 **ZOOM** button (25)

*\* These buttons function as the number buttons when pressed with SHIFT (S) button.*



# Preparing the remote controller

Before using the remote controller:

- Aim the remote controller directly at the remote sensor on the main unit. Make sure there is no obstacle in between.

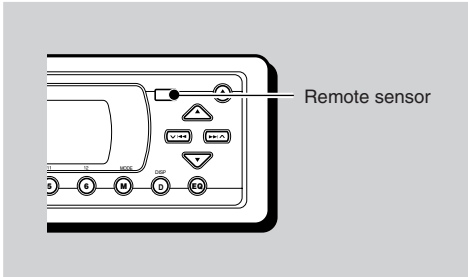

- Do not expose the remote sensor to strong light (direct sunlight or artificial lighting).

## Installing the battery

When the controllable range or effectiveness of the remote controller decreases, replace the battery.

### 1. Remove the battery holder.

- 1) Push out the battery holder in the direction indicated by the arrow using a ball-point pen or a similar tool.
- 2) Remove the battery holder.

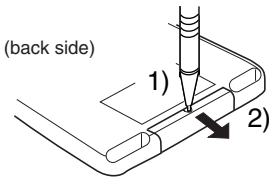

### 2. Place the battery.

Slide the battery into the holder with the + side facing upwards so that the battery is fixed in the holder.

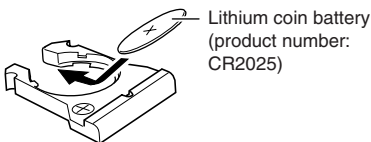

### 3. Return the battery holder.

Insert again the battery holder pushing it until you hear a clicking sound.

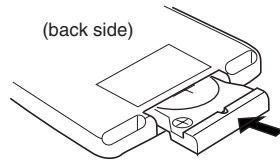

#### WARNING:

- Store the battery in a place where children cannot reach.  
*If a child accidentally swallows the battery, consult a doctor immediately.*
- Do not recharge, short, disassemble or heat the battery or dispose of it in a fire.  
*Doing any of these things may cause the battery to give off heat, crack or start a fire.*
- Do not leave the battery with other metallic materials.  
*Doing this may cause the battery to give off heat, crack or start a fire.*
- When throwing away or saving the battery, wrap it in tape and insulate; otherwise, the battery may start to give off heat, crack or start a fire.
- Do not poke the battery with tweezers or similar tools.  
*Doing this may cause the battery to give off heat, crack or start a fire.*

#### CAUTION:

*DO NOT leave the remote controller in a place (such as dashboards) exposed to direct sunlight for a long time. Otherwise, it may be damaged.*



# BASIC OPERATIONS

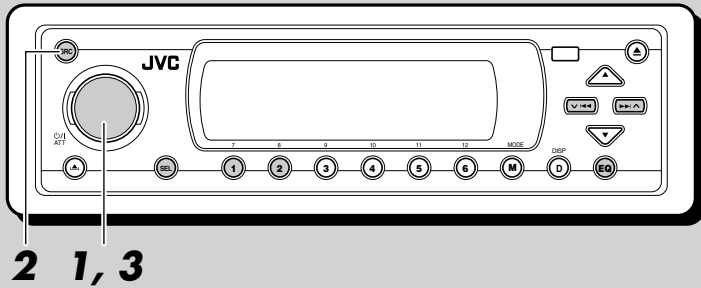

## Turning on the power

### 1 Turn on the power.

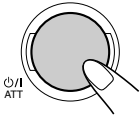

#### Note on One-Touch Operation:

When you select a source in step 2 below, the power automatically comes on. You do not have to press this button to turn on the power.

### 2 Select the source.



Each time you press the button, the source changes as follows.

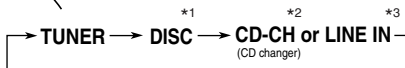

To operate the tuner (FM or AM), see pages 11 – 15.

To play a disc, see pages 16 – 46.

To operate the CD changer, see pages 59 – 64.

To operate the external component (LINE IN), see page 65.

\*1 If a disc is not in the loading slot, you cannot select "DISC" as the source to play.

\*2 Without connecting a CD changer, you cannot select it as the source to play.

\*3 To select "LINE IN," select "Line In" for the "Ext Input" setting on page 53.

### 3 Adjust the volume.



Volume level appears.



Current sound (iEQ) mode (see page 48)

### 4 Adjust the sound as you want. (See pages 47 – 49.)

#### Note:

While playing a source, you can also show the level meter on the display. For details, see "Activating the level meter" on page 10.

### To drop the volume in a moment

Press **ATT** briefly while listening to any source. "ATT" starts flashing on the display, and the volume level will drop in a moment.

To resume the previous volume level, press the button briefly again.

- If you turn the control dial, you can also restore the sound.

### To turn off the power

Press **ATT** for more than 1 second.

- If you turn off the power while listening to a disc, playback will start from where playback has been stopped previously, next time you turn on the power.





# Canceling the display demonstration

When shipped from the factory, display demonstration has been activated, and starts automatically when no operations are done for about 20 seconds.

- It is recommended to cancel the demonstration before you use the unit for the first time.

To cancel the display demonstration, follow the procedure below:

- 1 Press and hold SEL (select) for more than 2 seconds so that one of the PSM items appears on the display. (PSM: see page 51.)**



- 2 Press number button 1 to select "MOVIE"—Movie category of the PSM settings.**

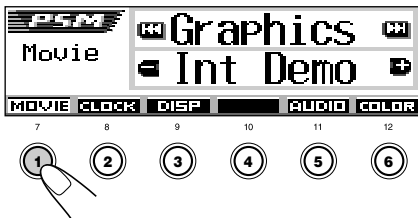

The "Graphics" setting screen appears on the display.

- 3 Select "Off."**

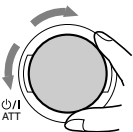

- 4 Finish the setting.**



To activate the display demonstration, repeat the same procedure and select "All Demo" or "Int Demo" in step 3.

- For more details, see "To set the movie demonstration—Graphics" on page 52.

# Setting the clock

You can also set the clock system to 24 hours or 12 hours.

- 1 Press and hold SEL (select) for more than 2 seconds so that one of the PSM items appears on the display. (PSM: see page 51.)**



- 2 Press number button 2 to select "CLOCK"—Clock category of the PSM settings.**

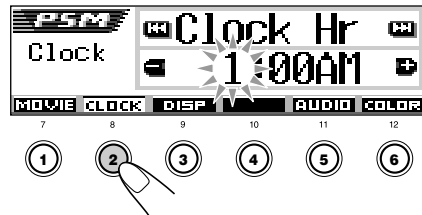

The "Clock Hr" setting screen appears on the display.

- 3 Adjust the hour.**

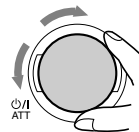

- 4 Set the minute.**

- 1 Select "Clock Min (minute)."
- 2 Adjust the minute.

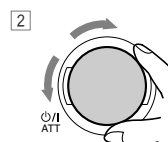
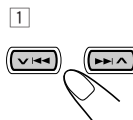

CONTINUED ON THE NEXT PAGE



### 5 Set the clock system.

- 1 Select "24H/12H."
- 2 Adjust "24Hours" or "12Hours."



### 6 Finish the setting.



To check the current clock time when the unit is turned off, press DISP (D).

The power turns on and the clock time is shown for about 5 seconds, then the power turns off.

## Activating the level meter

You can show the level meters on the display while playing any source. This unit is equipped with three level meter patterns.

- There is a time limit in doing the following procedure. If the setting is canceled before you finish, start from step 1 again.

### 1 Press EQ (equalizer) twice.



Last selected level meter appears on the display.

- If you press the button only once, the sound selection screen appears (see page 48).

### 2 Select the level meter pattern you want.



As you turn the control dial, the level meters change as follows:

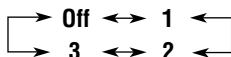

### Meter 1:

The audio level meter fluctuates vertically.

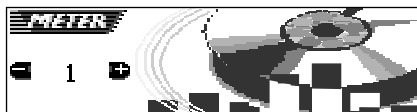

### Meter 2:

The speaker on the display vibrates as input audio level changes.

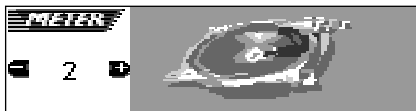

### Meter 3:

The left and right audio level meters appear.

- If the display pattern is changed, only one audio level meter will be shown.

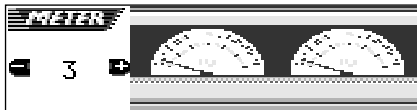

### Off:

No level meter is shown. The source animation appears.

#### NOTICE:

The illustrations of the display used in this manual are mainly of the initial setting when shipped from the factory. If you have changed the display patterns or some PSM items, the actual displays you see will be different.

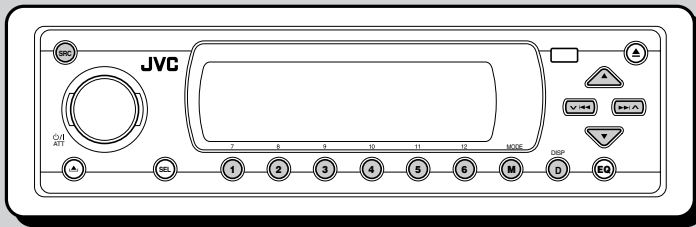

The operations of this section are mainly explained using the buttons on the control panel. When the remote controller can be used for the same operations, it is then explained.

## Listening to the radio

You can use either automatic searching or manual searching to tune in to a particular station.

### Searching for a station automatically: Auto search

This operation is also possible from the remote controller.

#### 1 Select the band (FM1 – 3, AM).



- 1 Press SRC (source) repeatedly to select the tuner.
- 2 Press and hold SRC. Each time you press and hold the button, the band changes.

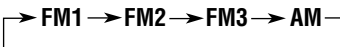

Selected band appears.



Lights up when receiving an FM stereo broadcast with sufficient signal strength.

#### Note:

*This receiver has three FM bands (FM1, FM2, FM3). You can use any one of them to listen to an FM broadcast.*

#### 2 Start searching for a station.

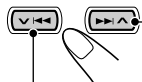

To search for stations of higher frequencies



To search for stations of lower frequencies

When a station comes in, searching stops.

**To stop searching before a station is received,** press the same button you have pressed for searching.

#### When using the remote controller

- 1 Press FM or AM.
  - When selecting the FM bands, press FM repeatedly until the band you want is selected.
- 2 Press ►► or ◀◀ to start searching.





## Searching for a station manually: Manual search

### 1 Select the band (FM1 – 3, AM).



- 1 Press SRC (source) repeatedly to select the tuner.
- 2 Press and hold SRC. Each time you press and hold the button, the band changes.

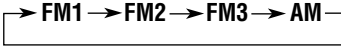

**Note:**

This receiver has three FM bands (FM1, FM2, FM3). You can use any one of them to listen to an FM broadcast.

### 2 Press and hold **▶▶**, **▲** or **▼**, **◀◀** until “Manual Search” starts flashing on the display.

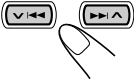

### 3 Tune in to a station you want while “Manual Search” is flashing.

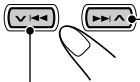

To tune in to stations of higher frequencies

To tune in to stations of lower frequencies

- If you release your finger from the button, the manual mode automatically turns off after 5 seconds.
- If you hold down the button, the frequency keeps changing (in 50 kHz intervals for FM and 9 kHz for AM) until you release the button.

## When an FM stereo broadcast is hard to receive:

1 Press MODE (M) to enter the functions mode while listening to an FM stereo broadcast. “Mode” appears on the display.



2 Press number button 1 to select “Mono On” while “Mode” is still on the display. Each time you press the button, “Mono On” and “Mono Off” appears alternately.

See page 30 for this function.

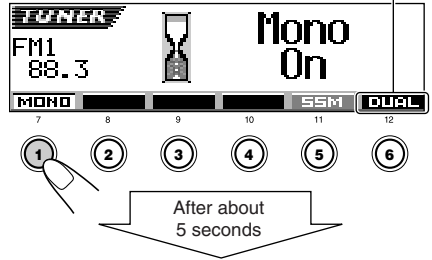

The display returns to the source indication screen.



When “Mono On” is selected, the MONO indicator appears, and the sound you hear becomes monaural but the reception will be improved.

## Storing stations in memory

You can use one of the following two methods to store broadcasting stations in memory.

- Automatic preset of FM stations: SSM (Strong-station Sequential Memory)
- Manual preset of both FM and AM stations

### FM station automatic preset: SSM

You can preset 6 local FM stations in each FM band (FM1, FM2, and FM3).

#### 1 Select the FM band (FM1 – 3) you want to store FM stations into.



- 1 Press SRC (source) repeatedly to select the tuner.
- 2 Press and hold SRC. Each time you press and hold the button, the band changes.

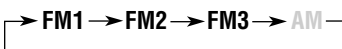

#### Note:

This receiver has three FM bands (FM1, FM2, FM3). You can use any one of them to listen to an FM broadcast.

#### 2 Start automatic preset.

- 1 Press MODE (M) to enter the functions mode.

MODE

“Mode” appears on the display.



- 2 Press and hold number button 5 while “Mode” is still on the display.

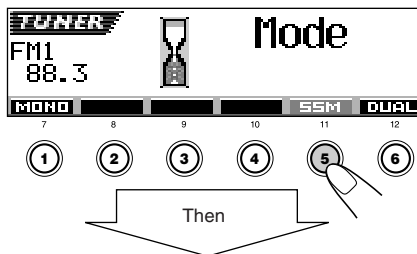

“-SSM-” appears, then disappears when automatic preset is over.

Local FM stations with the strongest signals are searched and stored automatically in the band number you have selected (FM1, FM2, or FM3). These stations are preset in the number buttons—No.1 (lowest frequency) to No.6 (highest frequency).

### Manual preset

You can preset up to 6 stations in each band (FM1, FM2, FM3, and AM) manually.

Ex.: Storing an FM station of 92.5 MHz into the preset number 1 of the FM1 band.

#### 1 Select the band (FM1 – 3, AM) you want to store stations into (in this example, FM1).



- 1 Press SRC (source) repeatedly to select the tuner.
- 2 Press and hold SRC. Each time you press and hold the button, the band changes.

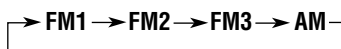



## 2 Tune in to a station (in this example, of 92.5 MHz).

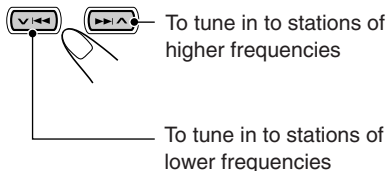

## 3 Press and hold the number button (in this example, 1) for more than 2 seconds.



The display pattern automatically changes like the above pattern (see page 15). The preset number flashes for about 5 seconds, then the previous display pattern resumes.

## 4 Repeat the above procedure to store other stations into other preset numbers.

### Notes:

- A previously preset station is erased when a new station is stored in the same preset number.
- Preset stations are erased when the power supply to the memory circuit is interrupted (for example, during battery replacement). If this occurs, preset the stations again.

## Tuning in to a preset station

You can easily tune in to a preset station. Remember that you must store stations first. If you have not stored them yet, see “Storing stations in memory” on pages 13 and 14.

### Selecting a preset station directly

#### 1 Select the band (FM1 – 3, AM).



- 1 Press SRC (source) repeatedly to select the tuner.
- 2 Press and hold SRC. Each time you press and hold the button, the band changes.

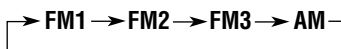

#### 2 Select the number (1 – 6) for the preset station you want.

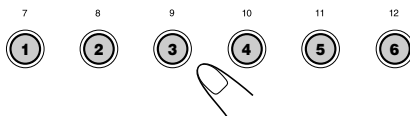

### Note:

You can also use the ▲ (up) or ▼ (down) button on the unit to select the next or previous preset stations. Each time you press the ▲ (up) or ▼ (down) button, the next or previous preset station is tuned in.

### When using the remote controller

#### 1 Press FM or AM.

- When selecting the FM bands, press FM repeatedly until the band you want is selected.



#### 2 Press the number buttons (1 to 6) while holding SHIFT (S).



### Note:

You can also use the PRESET (FOLDER) ▲ / ▼ buttons for selecting a preset station.

## Selecting a preset station using the preset station list

If you forget which stations are stored in which preset numbers, you can check the preset station list, then select your desired station.

### 1 Select the band (FM1 – 3, AM).



- 1 Press SRC (source) repeatedly to select the tuner.
- 2 Press and hold SRC. Each time you press and hold the button, the band changes.

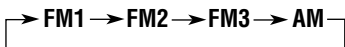

### 2 Press and hold ▲ (up) or ▼ (down) until the preset station list for the current band (FM1, FM2, FM3, or AM) appears on the display.

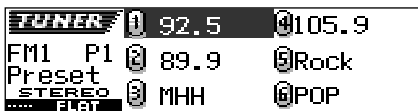
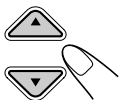

#### Notes:

- You can show the other FM band preset station lists (FM1, FM2, or FM3) by pressing ▲ (up) or ▼ (down).
- If a name has been assigned to a station (see page 57), it will be shown instead of the station frequency.

### 3 Select the number (1 – 6) for the preset station you want.

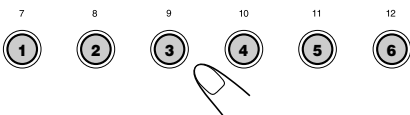

## Changing the display pattern

By pressing DISP (D), you can change the information shown on the display.



Each time you press the button, the display patterns change as follows:



Appears only when selecting a preset station number.



Clock time









If a name has been assigned to a station, it will be shown instead of "NO NAME."





# PLAYABLE DISCS

## Discs you can play:

Disc Type	Mark (Logo)	Video Format	Region Code*
DVD Video	 	NTSC/PAL	3 ALL
Video CD	 		_____
Audio CD	 	_____	_____
MP3 disc	CD-Rs or CD-RWs including MP3 files with the file extension code <mp3>. They must be recorded in the format compliant with ISO 9660 Level 1, ISO 9660 Level 2, Romeo, and Joliet.		

- On some discs, the actual operations may be different from what is explained in this manual.
- The following discs cannot be played back;
  - DVD-Audio, DVD-ROM, DVD-RAM, DVD-R, DVD-RW, CD-ROM, CD-I (CD-I Ready), Photo CD, etc.
 Playing back these discs will generate noise and damage the speakers.

### \* Note on Region Code

DVD players and DVD Video discs have their own Region Code numbers. This unit can only play back DVD discs whose Region Code numbers include "3."



Examples:

### If you insert a DVD Video disc of an incorrect Region Code

"REGION CODE ERROR!" appears on the monitor, and "Please Eject" flashes on the display. (If the control panel is not yet closed, the disc ejects automatically.)

## Disc structure

### DVD

A DVD disc consists of **Titles**, and each title may be divided into **Chapters**.

For example, if a DVD disc contains some movies, each movie may have its own title number, and it may be further divided into chapters.

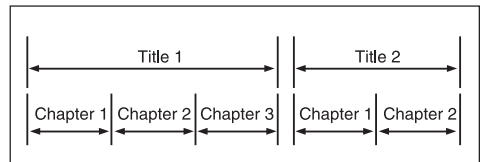

### Video CD (VCD) and Audio CD (CD)

On the other hand, a VCD or CD consists of **Tracks**.

In general, each song has its own track number. (On some discs, each track may also be divided by **Indexes**.)

When playing back a VCD with the Playback Control (PBC) function, you can select what to view using the menu shown on the monitor. (While operating a VCD using the menu, some of the functions such as Repeat and Track Search may not work.)



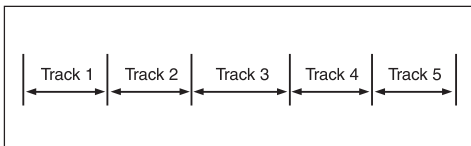

### MP3 discs

MP3 is an abbreviation of Motion Picture Experts Group 1 (or MPEG-1) Audio Layer 3. MP3 is simply a file format with a data compression. By using MP3 format, one CD-R or CD-RW can contain 10 times as much data as a regular CD can.

On an MP3 disc, files (also called “tracks” and both words are used interchangeably in this manual) are usually grouped into a folder. Folders can also include other folders, creating hierarchical layers of folders.

This unit can recognize up to 150 files per folder, and up to 99 folders per disc (up to 14,850 files). The unit ignores those exceeding the maximum number and cannot play them back.

- All folders on the disc are counted in the total number of 150, even a folder which does not include any MP3 files.

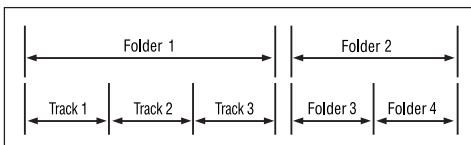

### Notes for MP3 disc

- MP3 discs require a longer readout time, which differs due to the complexity of the folder/file configuration.
- This unit supports “multi-session” discs.
- This unit cannot play “packet write” discs.
- The unit can play MP3 files with the correct extension code—<.mp3> (case insensitive—any combination of upper and/or lower is acceptable)
- It is recommended that MP3 files be recorded at a sample rate of 44.1 kHz and at a data transfer rate of 128 kbps.
- For more information about MP3 discs, see “A Guide to MP3” (separate volume).

### About sounds reproduced through the rear terminals

#### • Through the analog terminals (Speaker out/LINE OUT/2nd AUDIO OUT):

2-channel signal is emitted.

When playing a multi-channel encoded disc, multi-channel signals are downmixed.

(AUDIO—ANALOG DOWN MIX: see page 46)

#### • Through DIGITAL OUT (optical):

Digital signals (Linear PCM, Dolby Digital\*, DTS\*\*, MPEG Multichannel) are emitted through this terminal. (For more details, see page 71.)

To reproduce multi-channel sounds such as Dolby Digital and DTS, connect an amplifier or a decoder compatible with these multi-channel sources to this terminal, and set “DIGITAL AUDIO OUTPUT” to the correct value. (See page 46.)

#### • About Dual Zone

While you are listening to the radio, CD changer, or external component through the speakers built into your car compartment, you can listen to the playback sound of this DVD/CD player using the headphones connected to the 2nd AUDIO OUT plug at the same time.

- For details, see “DUAL ZONE OPERATIONS” on page 30.

\* Manufactured under license from Dolby Laboratories. “Dolby” and the double-D symbol are trademarks of Dolby Laboratories.

\*\* “DTS” and “DTS Digital Out” are trademarks of Digital Theater Systems, Inc.



# BASIC DISC PLAYBACK

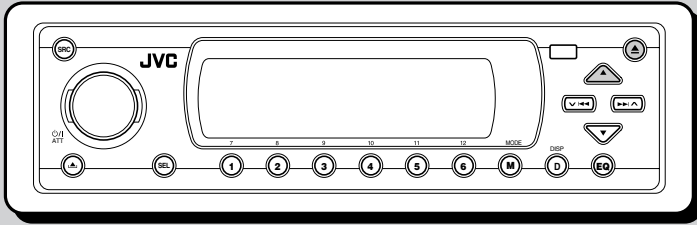

The following marks used in this manual indicate the playable discs.

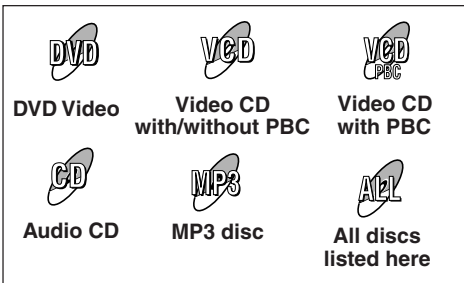

### Before performing any operations, make sure the following...

- To watch the playback pictures, select the appropriate video system (NTSC or PAL) to match it to the connected monitor. (See page 53.)
- Turn on the monitor for playing a DVD or VCD. If you turn on the monitor, you can also control the CD and MP3 playback by referring to the monitor screen.
- For DVD playback, you can change the Setup Menu setting to your preference. (See pages 43 – 46.)**
- When you want to operate the DVD/CD player using the buttons on the control panel, see “OTHER DISC OPERATIONS” on pages 35 to 42.

If “⊘” appears on the monitor when pressing a button, the disc cannot accept an operation you have tried to do.

- In some cases, without showing “⊘,” operations will not be accepted.

## Starting playback

### 1 Open the control panel.

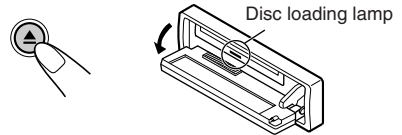

### 2 Insert a disc into the loading slot.

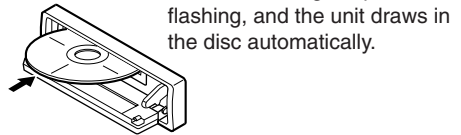

DO NOT insert a disc while the disc loading lamp is flashing\* or is not lit\*\*.

- \* Flashing: while loading or ejecting a disc
- \*\* Not lit: when a disc has been loaded.

### 3 Close the control panel by hand.

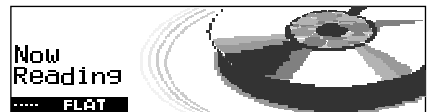
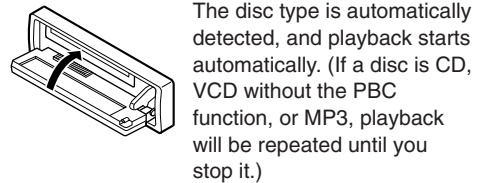

- If a menu appears while playing a DVD or VCD with PBC function, see “Menu operations” on page 24.



### • Display indications when inserting a DVD:

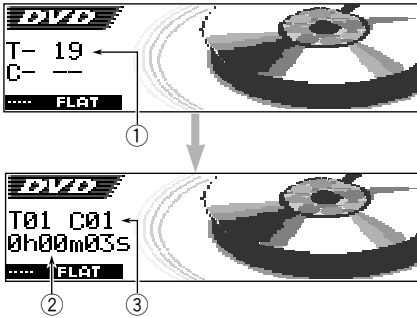

- ① Total title number
- ② Elapsed playing time of the current title
- ③ Current title number and chapter number

### • Display indications when inserting a VCD or CD:

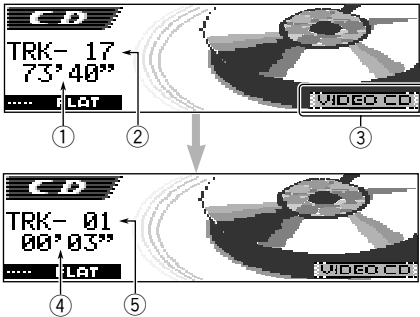

- ① Total playback time of the disc
- ② Total track number
- ③ VIDEO CD indicator: appears only when playing back a Video CD.
- ④ Elapsed playing time of the current track
- ⑤ Current track number

### • Display indications when inserting an MP3 disc

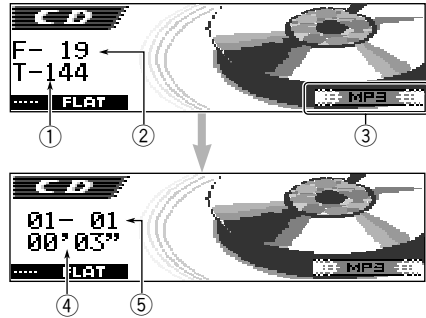

- ① Total track number
- ② Total folder number
- ③ MP3 indicator
- ④ Elapsed playing time of the current track
- ⑤ Current folder number and track number

#### Note:

When a new folder starts playing, its folder name is shown on the display (the display pattern automatically changes for a while—see page 42.)

#### Caution:

When you start playing a Mixed-CD, playback will stop at the beginning of the first track (with [00'00"] shown for the elapsed playing time). If this happens, skipping to the second track or higher will start playback from the newly selected track.

- For details about the Mixed-CD, refer to "A Guide to MP3" (separate volume).

#### Notes:

- When a disc is already in the loading slot, selecting "DISC" as the source starts disc play.
- This unit cannot read or play an MP3 file without the extension code <mp3>.
- When a disc is inserted upside down, the disc automatically ejects (if the control panel is open).  
If the control panel is closed, the source changes to the previously selected source, "Please Eject" flashes on the display.



## To stop playback temporarily

Press **II** on the remote controller.  
“Pause” flashes on the display.



- For DVD and VCD only: A still picture appears.

**Frame by Frame Playback**—You can advance the still picture frame by frame by pressing the **II** repeatedly.

To resume normal speed, press **▶**.

**Slow Motion Playback**— You can advance the still picture in slow motion by pressing **▶▶** or **◀◀**. Each time you press the button, the search speed changes as follows:



1/32 → 1/16 → 1/8 → 1/4 → 1/2

To resume normal speed, press **▶**.

### Notes:

- No sound comes out during Reverse Slow Motion Playback
- When playing a VCD, Reverse Slow Motion Playback is prohibited.

## To replay the previous scenes

### —One Touch Replay

Press **▶** on the remote controller (or **▲** (up) on the control panel) during play.

The playback position moves back about 10 seconds before the current position.



### Notes:

- This function works only within the same title.
- For some DVDs, this function does not work.

## To stop playback

Press **■** on the remote controller.

- Except for MP3 discs: This unit can remember the end point (until the disc is ejected), and when you start playback again, playback begins from where it has been stopped. (Resume play)
- For MP3 discs: This unit can remember the last playing track (until the disc is ejected), and when you start playback again, playback begins from the beginning of the same track.

## To eject a disc

Press **▲** on the control panel.

Playback stops and the control panel flips down. The disc comes out of the loading slot.

## Locating a particular title/ chapter/track

### To go to the next or previous chapter/tracks



- For DVD: During play or pause



Press **▶▶** to go ahead to the beginning of the next chapter/track. Each time you press the button, the beginning of the next chapter/track is located (and played back).

Press **◀◀** to go back to the beginning of the current chapter/track.

Each time you press the button, the beginning of the previous chapter/track is located (and played back).

### Note:

Playback will not start automatically if you locate the chapter/track while a disc is pausing or not playing.



## To locate a particular title/chapter/track directly



- For DVD: During play or pause—select a chapter  
While stopped—select a title
- For VCD: While PBC (see page 24) is not in use.

### From the remote controller:

While holding SHIFT (S), press number buttons to select a title, chapter, or track number you want.

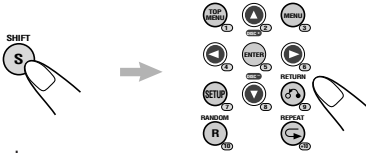

Examples:

- To select number 5, press 5 while pressing SHIFT (S).
- To select number 10, press 10 while pressing SHIFT (S).
- To select number 23, press +10, +10, then 3 while pressing SHIFT (S).

### Notes:

- If you directly select the track number for a VCD with the PBC function while it is not playing, playback starts with PBC function canceled. (See page 24).
- Playback will not start automatically if you select a chapter or track during pause.

## Locating a particular folder

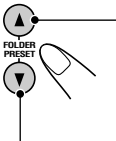

Press FOLDER (PRESET) ▲ to select the next folder. Each time you press the button, the next folder is located and the first track in it starts playing.

Press FOLDER (PRESET) ▼ to select the previous folder. Each time you press the button, the previous folder is located and the first track in it starts playing.

### Note:

If a folder does not contain any MP3 tracks, it is skipped.

## On-screen guide icons



During play, the following guide icons may appear for a while on the monitor.

- : Appears at the beginning of a scene containing multi-subtitle languages (for DVD only).
- : Appears at the beginning of a scene containing multi-audio languages (for DVD only).
- : Appears at the beginning of a scene containing multi-angle views (for DVD only).
- : Appears when you press ►.
- : Appears when you press II.
- : Appears when you start forward slow motion. (Slow motion speed also appears.) (for DVD and VCD only).
- : Appears when you start reverse slow motion. (Slow motion speed also appears.) (for DVD only).
- : Appears when you start forward search. (Search speed also appears.)
- : Appears when you start reverse search. (Search speed also appears.)
- : Appears when you select repeat mode (see page 28).



# DVD/VCD SPECIAL FUNCTIONS

ENGLISH

## Selecting subtitles



While playing a disc containing subtitles in different languages, you can select which subtitle to display.

- You can also set your favorite subtitle language as the initial language shown on the monitor. (See pages 43 to 45.)

### Select a desired subtitle language.



The following pop-up window appears on the monitor. Each time you press the button, the subtitle language changes.

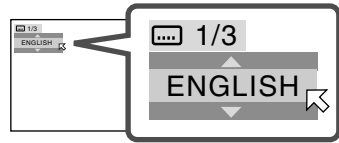

Ex. When the disc has 3 selections—  
English, French, Spanish and no subtitle (OFF)

### Notes:

- When the pop-up window is shown, you can also select the subtitle languages by pressing cursor buttons (▲/▼).
- For some DVDs and VCDs, changing the subtitle language without using the disc menu is prohibited.

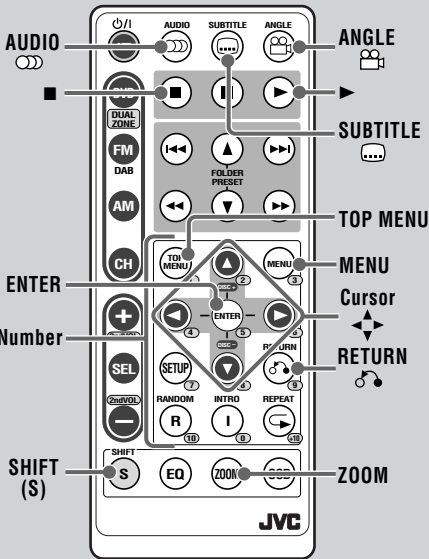



## Selecting audio languages



### For DVD:

While playing a disc containing multiple audio languages (ex. English, French, Spanish), you can select the language to listen to.

- You can also set your favorite language as the initial audio language. (See pages 43 to 45.)

### For VCD:

When you play a VCD, you can select the audio channel to play. This is convenient when playing a Karaoke VCD.

### Select a desired audio language (or audio channel).



The following pop-up window appears on the monitor. Each time you press the button, the audio language (or audio channel) changes.

#### • For DVD:

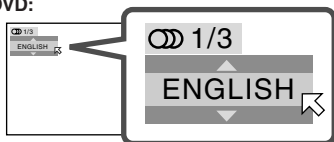

Ex. When the disc has 3 selections—English, French, and Spanish

#### • For VCD:

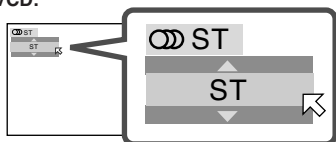

- ST: To listen to normal stereo (left/right) playback.
- L: To listen to the L (left) audio channel.
- R: To listen to the R (right) audio channel.

### Notes:

- When the pop-up window is shown, you can also select the audio languages (or audio channels) by pressing cursor buttons (▲/▼).
- For some DVDs and VCDs, changing the audio language (or audio channel) without using the disc menu is prohibited.

## Selecting multi-angle views



While playing a disc containing multi-angle views, you can view the same scene at different angles.

### Select a desired view angle.



The following pop-up window appears on the monitor. Each time you press the button, the view angle changes.

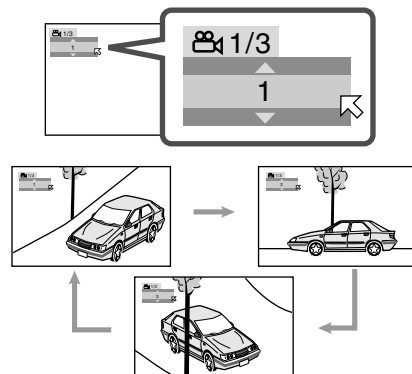

Ex.: When the disc has 3 multi-angle views

### Note:

When the pop-up window is shown, you can also select the multi-angle views by pressing cursor buttons (▲/▼).



# Menu operations



Menu-driven playback is possible while playing back a DVD with menu-driven features or a VCD with the PBC (PlayBack Control) function.

## While playing a DVD:

DVD discs generally have their own menus or title lists. A title list usually contains titles of movies and songs recorded. On the other hand, a menu usually contains various information about the disc and playback selections.

### 1 Press TOP MENU or MENU.

A title list or menu will appear on the monitor.

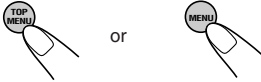

### 2 Select the item you want from the menu or the title list, by pressing cursor buttons (▲ / ▼ / ► / ◀) then ENTER.

The unit starts playback of the selected item.

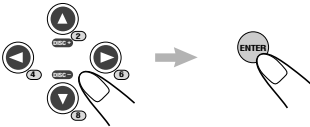

- On some discs, you can also select items by pressing the number buttons corresponding to the item numbers listed.

## To return to the previous menu

Press RETURN ↵.



## To cancel the title list or menu

Press TOP MENU or MENU.

If "⊘" appears on the monitor in step 1, the disc does not have a title list or menu.

## While playing a VCD:

The PBC (PlayBack Control) function allows you to operate the VCD using menus. When you start playback, a menu will automatically appear on the monitor.

- A menu may be a list of items, divided screens, or some moving pictures.

## Select the item you want from the menu.

- When a list of items is displayed on the monitor, press the number buttons to select an item.
- When "►" or "SELECT" is displayed on the monitor, press ► (or ENTER if pressing ► does not work) to start playback.

### How to select items using the number buttons

- To select number 5, press 5 while pressing SHIFT (S).
- To select number 10, press 10 while pressing SHIFT (S).
- To select number 23, press +10, +10, then 3 while pressing SHIFT (S).

## To return to the previous menu

Press RETURN ↵.



## To cancel the PBC playback

You can cancel the menu-driven operations (PBC function):

- 1 Press ■ to stop playback.
- 2 Press number buttons to select a track. Normal playback starts from the selected track.

To resume the PBC function again, press TOP MENU or MENU.

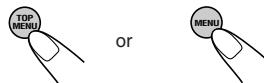





# Zoom in



You can zoom into a particular portion of the picture while playing a DVD or VCD.

## 1 Zoom in to the picture.



The pop-up window appears on the monitor to show the current magnification. Each time you press the button, magnification change as follows:

→ x 2 → x 4 → x 8 → x 1 → x 2 → x 4 → x 8 → ...

Ex. When "ZOOM x4" is selected

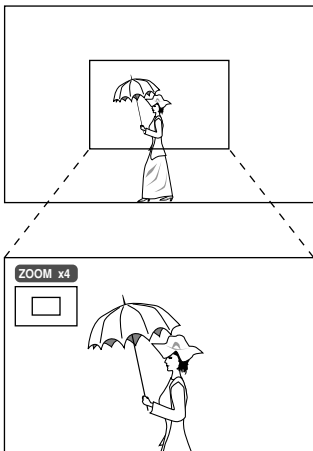

## 2 Move the zoomed-in portion on the monitor.

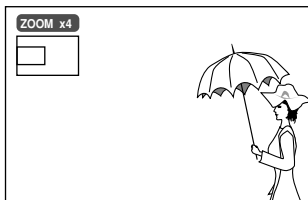

### Note:

While zoomed in, the picture may look coarse.

To cancel Zoom, press ENTER or press ZOOM repeatedly until "ZOOM x1" appears.



# ADVANCED DISC OPERATIONS

ENGLISH

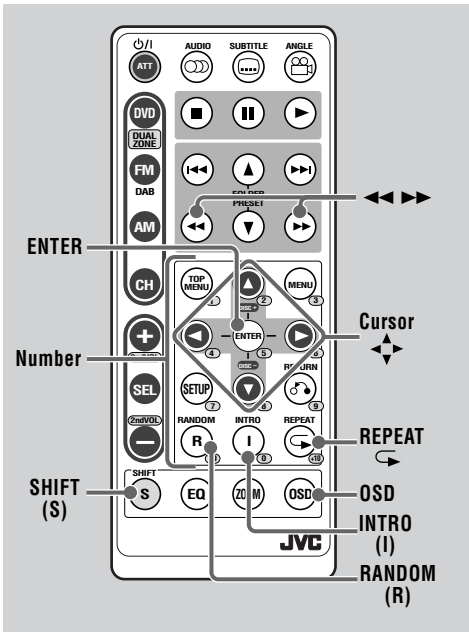

## Notes:

\* "x60" is only for DVD.

- When playing an MP3 disc, no sound comes out during Search.
- When playing a DVD or VCD, no sound comes out during x5, x10, x20, and x60 Search.
- Reverse Search stops automatically when it reaches the beginning of the disc. Playback resumes at normal speed.

## Time Search



You can start playing a particular point by specifying the elapsed playing time of the current title (for DVD) and of the disc (CD and VCD).

- For DVD: During play or pause.
- For VCD: While PBC (see page 24) is not in use.

### 1 Press OSD twice.



The on-screen bar appears on the monitor.

- For details on the on-screen bar, see pages 32 and 33.



### 2 Move to (Time Search), then press ENTER.

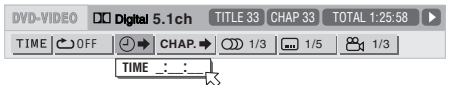

The time entry window appears.

### 3 Press number buttons (0 to 9) to enter the time while holding SHIFT (S).

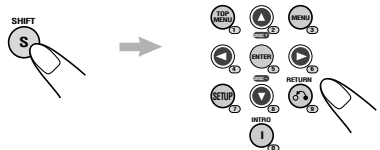

## Searching for a particular point

### Forward/Reverse Search



You can search for a particular point while playing a disc.

To fast-forward or reverse the chapter or track, press or while playing a disc.

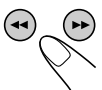

Each time you press the button, the search speed changes as follows:

x2 → x5 → x10 → x20 → x60\*

To resume normal speed, press .

When using the buttons on the control panel Press and hold ^ or v while playing a disc.

The search speed changes: x2 → x10.

- If you release the button, normal speed playback resumes.



### Example (for DVD VIDEO)

To play back from 2(H):34(M):00(S)  
Press number buttons 2, 3, then 4.

TIME 2 : 34 : \_\_

To play back from 58(M):00(S)

Press number buttons 0, 5, then 8.

TIME 0 : 58 : \_\_

### Example (for Video CD/Audio CD)

To play back from 23(M):40(S)

Press number buttons 2, 3, then 4.

TIME 23 : 4 \_

You do not have to press "0" to enter the trailing zeros.

### To correct a mistake

Press cursor button ◀ repeatedly to move back to the digit where you entered a wrong number, and reenter the correct one.

## 4 Finish entry.



The unit starts playback from the specified time.

To erase the on-screen bar, press OSD once.

## Chapter Search



You can select a specific chapter when a DVD is inserted.

## 1 Press OSD twice.



The on-screen bar appears on the monitor.

- For details about the on-screen bar, see pages 32 and 33.



## 2 Move [CHAP.] to [CHAP.], then press ENTER.



The chapter number entry window appears.

## 3 Press number buttons (0 to 9) to enter the chapter number while holding SHIFT (S).

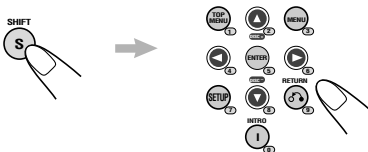

- To select number 5, press 5 while pressing SHIFT (S).
- To select number 10, press 1, then 0 while pressing SHIFT (S).
- To select number 23, press 2, then 3 while pressing SHIFT (S).

### To correct a mistake

- To correct a two digit number, enter the correct number again.
- To correct a single digit number, press 0 first, then enter the correct number.

## 4 Finish entry.



The unit starts playback from the selected chapter.

To erase the on-screen bar, press OSD once.



# Playing in various play modes

You can use any of three methods to activate various play modes.

- Using the direct buttons on the remote controller.
- Using the on-screen bar (see page 32).
- Using the buttons on the control panel (see page 38).

In the following explanation, how to use the direct buttons on the remote controller is explained.

## Repeat Play



You can repeat a title, chapter, track, or disc endlessly.

- For VCD: While PBC (see page 24) is not in use.

### Select the repeat mode you want.



The menu bar icon appears on the monitor to show the selected mode. Each time you press the button, the repeat mode changes as follows:

- For DVD:

- CHAP: Current (or specified) chapter will be repeated.
  - CHAP indicator appears on the monitor.
- TITLE: Current title will be repeated.
  - TITLE indicator appears on the monitor.
- OFF: Repeat Play is canceled.
  - OFF indicator appears on the monitor.

- For VCD/CD:

- TRACK: Current (or specified) track will be repeated.
  - TRACK indicator appears on the monitor.
- OFF: Track Repeat is canceled. All the tracks in the disc will be repeated.
  - OFF indicator appears on the monitor.

- For MP3:

- TRACK: Current (or specified) track will be repeated.
  - "REPEAT TRACK" appears on the MP3 CONTROL screen (see page 34).
- FOLDER: All the tracks in the current (or specified) folder will be repeated.
  - "REPEAT FOLDER" appears on the MP3 CONTROL screen (see page 34).
- OFF: Track Repeat and Folder Repeat is canceled. All the tracks in the disc will be repeated.

### Notes:

- On some DVDs, Repeat Play may be canceled by the disc itself.
- On CD, VCD, and MP3 discs, Repeat Play mode cannot be turned off.
- Repeat Play mode will be canceled when you start playing back a VCD with the PBC function.



## Random Play



You can play back tracks on a disc (or in a folder for MP3 discs) at random.

- For VCD: While PBC (see page 24) is not in use.

### Select the random mode you want.



The menu bar icon appears on the monitor to show the selected mode. Each time you press the button, the random mode changes as follows:

#### • For CD/VCD:

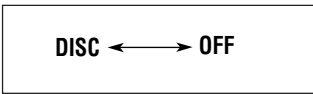

- DISC: All the tracks in the disc will be played at random.
  - **RND.** indicator on the menu bar (see page 33) is highlighted in blue.
- OFF: Random Play is canceled.

#### • For MP3:

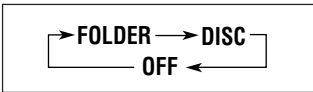

- FOLDER: All the tracks in the folder will be played at random, then move to the next folder and so on.
  - “RND FOLDER” appears on the MP3 CONTROL screen (see page 34).
- DISC: All the tracks in the disc will be played at random.
  - “RND DISC” appears on the MP3 CONTROL screen (see page 34).
- OFF: Random Play is canceled.

## Intro Scan



You can play back the first 15 seconds of each track sequentially.

- For VCD: While PBC (see page 24) is not in use.

### Select the intro scan mode you want.



The menu bar icon appears on the monitor to show the selected mode. Each time you press the button, the intro scan mode changes as follows:

#### • For CD/VCD:

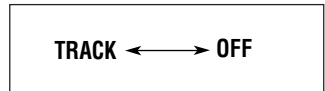

- TRACK: The beginnings of all the tracks in the disc will be played.
  - **INTRO** indicator on the menu bar (see page 33) is highlighted in blue.
- OFF: Intro Scan is canceled.

#### • For MP3:

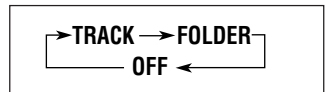

- TRACK: The beginnings of all the tracks in the disc will be played.
  - “INTRO TRACK” appears on the MP3 CONTROL screen (see page 34).
- FOLDER: The beginnings of the first tracks in all folders will be played.
  - “INTRO FOLDER” appears on the MP3 CONTROL screen (see page 34).
- OFF: Intro Scan is canceled.



# DUAL ZONE OPERATIONS

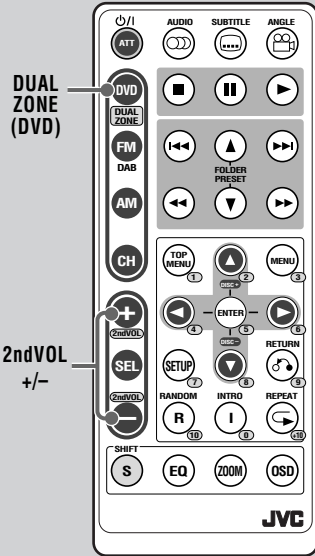

- DO NOT put on the headphones while driving a car. It is dangerous to shut off the outside sounds while driving.
- DO NOT put on the headphones before adjusting the headphone volume level properly; otherwise, it may damage your hearing.

For Dual Zone operations, aim the remote controller at the remote sensor on the receiver as usual, not at the monitor.

## Listening with headphones



By connecting headphones to the 2nd AUDIO OUT plug on the rear, you can listen to the playback sound through the DVD/CD player while listening to another source (except AM) through the speakers.

You can activate Dual Zone while listening to any source.

- You can operate the DVD/CD player using the remote controller.

### 1 While holding SHIFT (S), press DUAL ZONE (DVD) to activate Dual Zone.



Each time you press DUAL ZONE (DVD), Dual Zone is turned on and off alternately.

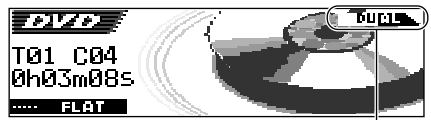
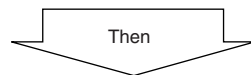

DUAL indicator appears.

The source automatically changes to "DISC."

**To select a different source (except AM) to listen through the speakers**, press SRC on the control panel. By using the buttons on the control panel, you can operate the newly selected source without affecting Dual Zone operations.



## 2 Adjust the headphone volume through the 2nd AUDIO OUT plug.



## 3 Operate the DVD/CD player using the remote controller by referring to the monitor screen.

- When Dual Zone is in use, you can only operate the DVD/CD player using the remote controller.
- To control the other sources (except AM) while Dual Zone is activated, use the buttons on the control panel.**

### On the control panel:

You can also activate and deactivate Dual Zone, but can neither control the DVD/CD player nor adjust the headphone volume level.

- **To adjust the headphone level,** use the remote controller.

- 1 Press MODE (M) to enter the functions mode while listening to any source.  
“Mode” appears on the display.



- 2 Press number button 6 while “Mode” is still on the display.

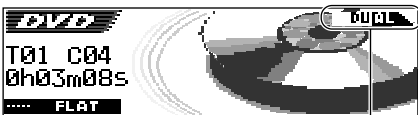
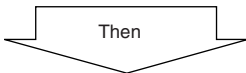
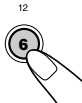

DUAL indicator appears.

The source automatically changes to “DISC.”

**To cancel Dual Zone operations,** repeat steps **1** and **2** (“Dual Zone Off” appears on the display.)

### When the sounds through the rear speakers are troublesome while listening with the headphones

You can deactivate the rear speaker sound output.

- See also “Changing the general settings (PSM)” on page 50.

- 1 Press and hold SEL (select) for more than 2 seconds so that one of the PSM items appears on the display.
- 2 Press number button 5 to select “AUDIO”—Audio category of the PSM settings.
- 3 Press ►►| ▲ or ▼ |◄◄ to select “Rear SPK.”
- 4 Turn the control dial counterclockwise to select “Off.”
- 5 Press SEL (select) to finish the setting.

**To reactivate the rear speakers,** repeat the same procedure and select “On” in step 4 by turning the control dial clockwise.



# OSD DISC OPERATIONS

ENGLISH

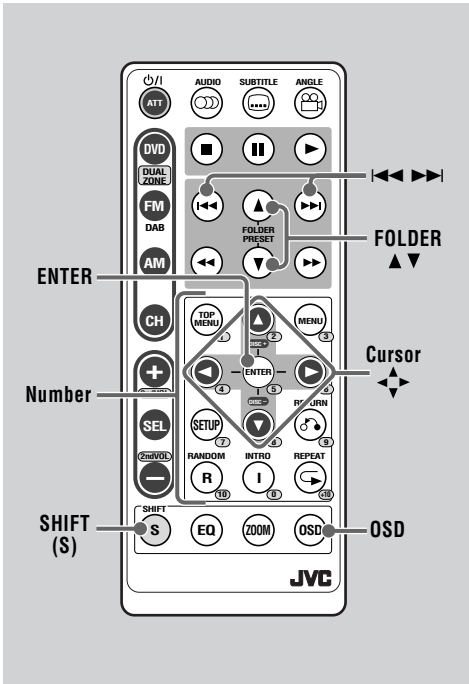

## Operations on the monitor screen



You can show the on-screen bar on the monitor, and operate the disc using the on-screen bar.

### Basic procedure for DVD, VCD and CD

#### 1 Press OSD once.



A status bar for the type of disc inserted appears on the monitor.  
• For details, see the left column.

**Note:**

When you start playing a CD, the status bar automatically appears.

#### 2 Press OSD again.



A menu bar appears under the status bar.  
• For details about the items on the menu bar, see page 33.

• For DVD



• For VCD



• For CD



**Note:**

While playing a CD Text, the disc information will also be shown on the monitor. (The maximum number of the characters shown on the monitor is 64, while 255 characters on the display of the receiver.)

**Status bars for DVD, VCD, and CD**

• For DVD

• For VCD/CD

- ① Disc type—DVD-VIDEO, VCD, CD
- ② Audio signal format type (only for DVD)
- ③ Current title number (only for DVD)
- ④ Current chapter number (only for DVD)
- ⑤ Time information
- ⑥ Current operation mode—▶, ■, ■, ▶▶, etc.
- ⑦ Current track number

**Note:**

While operating an MP3 disc on the monitor screen, see page 34.





### 3 Move to an item on the menu bar, then press ENTER.



The pull-down window for the selected items appears.



When you select **INTRO** or **RND.**, the pull-down window does not appear. Skip the following steps.

- See the following explanation.

### 4 Select an option or enter a chapter number.

- For details, see the following explanation for each item.

### 5 Finish the setting.



The pull-down window goes off.

To erase the on-screen bar, press OSD once.

## What you can do on the on-screen bars

**TIME** Change the time information on the status bar. Each time you press ENTER in step 4, the following time information alternately appears.

#### For DVD:

- TOTAL: Current title elapsed time
- T.REM: Current title remaining time
- TIME: Current chapter elapsed time
- REM: Current chapter remaining time

#### For VCD and CD:

- TIME: Current chapter elapsed time
- REM: Current track remaining time
- TOTAL: Disc elapsed time
- T.REM: Disc remaining time

 Select the Repeat Play modes. Each time you press cursor **▲** or **▼** in step 4, the repeat mode changes.

- For available repeat modes, see page 28.

 Activate Time Search. Press the number buttons to enter the elapsed time to a particular point in step 4.

- For details, see page 26.

**CHAP.**  Activate Chapter Search (only for DVD). Press the number buttons to enter a chapter number in step 4.

- For details, see page 27.

 Select multi-audio sound (for DVD) or playback channel (for VCD). Each time you press cursor **▲** or **▼** in step 4, multi-audio or playback channel changes.

- For details, see page 23.

 Select the subtitles (only for DVD). Each time you press cursor **▲** or **▼** in step 4, the subtitles change.

- For details, see page 22.

 Select the multi-angle views (only for DVD). Each time you press cursor **▲** or **▼** in step 4, the multi-angle view change.

- For details, see page 23.

**INTRO** Turns on and off Intro Scan (only for VCD and CD). Each time you press ENTER in step 3, Intro Scan modes change.

- For details, see page 29.

**RND.** Turns on and off Random Play (only for VCD and CD). Each time you press ENTER in step 3, Random Play modes change.

- For details, see page 29.



## Basic procedure for MP3 discs



While playing an MP3 disc, the following MP3 CONTROL screen always shows on the monitor. By referring to this screen, you can easily operate the MP3 disc.

- Up to 32 characters can be shown for the file names on the monitor, while 64 characters on the display of the receiver.
- For more details about MP3 discs, refer to “A Guide to MP3” (separate volume).

**MP3 CONTROL screen**

The diagram shows the MP3 CONTROL screen layout. At the top, there are three callouts: 1 points to the REPEAT TRACK button, 2 points to the Time: 00:03:08 display, and 3 points to the Track: 01/30 (Total 128) display. Below these are three main panels. The left panel shows Folder: 01/10 with a list of folders (spring, summer, fall, winter, sea) and a callout 4 pointing to it. The middle panel shows Title: Begonia, Artist: Annie Lim, Album: Flowers, and a callout 5 pointing to it. The right panel shows Track: 01/30 (Total 128) with a list of tracks (begonia.mp3, german chamomile.mp3, kiwi fruit.mp3, orchard grass.mp3, pelunia.mp3, north pole.mp3, begonia2.mp3, german chamomile2.mp3, kiwi fruit2.mp3, orchard grass2.mp3, pelunia2.mp3, north pole2.mp3) and a callout 6 pointing to it. A cursor is shown highlighting the first track, begonia.mp3.

- 1 Currently activated play mode
- 2 Elapsed playing time of the current track
- 3 Cursor (highlighted position)
- 4 ID3 Tag information (see page 68)
- 5 Folder column—folder names  
(Ex. The first folder is selected out of 10 folders)
  - Only 5 folders can be listed at a time.
- 6 Track column—track names  
(Ex. The first track is selected out of 30 tracks in the current folder. 128 tracks are included in the disc)
  - Only 12 tracks can be listed at a time.

### Operations from the remote controller:

**To select (highlight) a “Folder” column or “Track” column on the screen,** press cursor ► or ◀.

**To select a folder,** press cursor ▲ or ▼ when the cursor (highlighted position) is in the “Folder” column.

If there are unshown folders, they will appear in this column as you selecting folders.

- By pressing FOLDER (PRESET) ▲ or FOLDER (PRESET) ▼, you can change the folder without respect to the cursor (highlighted) position.

**To select a track,** press cursor ▲ or ▼ when the cursor (highlighted position) is in the “Track” column.

If there are unshown tracks, they will appear in this column as you selecting tracks.

- By pressing ►► or ◀◀, you can change the tracks without respect to the cursor (highlighted) position.

**To select Repeat Play modes,** press REPEAT (↺) repeatedly until the Repeat Play mode you want appears on the screen.

- For details about the Repeat Play modes, see page 28.

**To select Random Play modes,** press RANDOM (R) repeatedly until the Random Play mode you want appears on the screen.

- For details about the Random Play modes, see page 29.

**To select Intro Scan modes,** press INTRO (I) repeatedly until the Intro Scan mode you want appears on the screen.

- For details about the Intro Scan modes, see page 29.

### Note:

When using the buttons on the control panel, you can use various methods for performing the above operations. These different methods are explained in “OTHER DISC OPERATIONS” on pages 35 to 42.

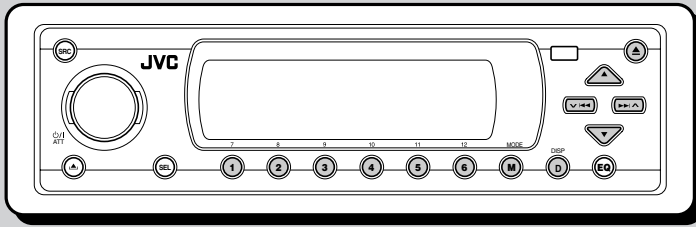

In this section, you can learn how to use the buttons on the control panel in order to operate the DVD/CD player.

## Basic disc playback

### To stop playback



Press **▼** (down).

- This unit can remember the end point, and when you start playback again, playback begins from where it has been stopped. (Resume play)

### To start playback again



Press **▲** (up).

Playback begins from where it has been stopped.

Normally disc playback automatically starts in the following cases:

- **When you insert a disc**  
Playback starts from the beginning of the disc.
- **When change the source to "DISC" (DVD/CD player) if a disc has been inserted**  
Playback starts from where it has been stopped. (Resume play)

#### Note:

If you press the button during DVD playback, the playback position moves back about 10 seconds before the current position. (See page 20: One Touch Replay)

### To eject a disc



Press **▲**.

Playback stops and the control panel flips down. The disc comes out of the loading slot.

### To fast-forward or reverse the chapter/track (Forward/Reverse Search)

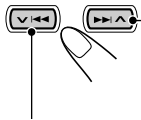

Press and hold **▶▶|▲**, while playing a disc, to fast-forward the chapter/track. The search speed changes: x2  $\Rightarrow$  x10.

Press and hold **▼|◀◀**, while playing a disc, to reverse the chapter/track. The search speed changes: x2  $\Rightarrow$  x10.

#### Notes:

- When playing an MP3 disc, no sound comes out during Search.
- When playing a DVD or VCD, no sound comes out during x10 Search.
- Reverse Search stops automatically when it reaches the beginning of the disc. Playback resumes at normal speed.

### To go to the next or previous chapter/tracks

- For DVD: During play or pause.

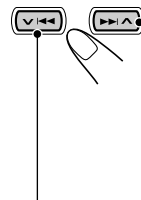

Press **▶▶|▲** briefly to go ahead to the beginning of the next chapter/track. Each time you press the button consecutively, the beginning of the next chapter/track is located and played back.

Press **▼|◀◀** briefly to go back to the beginning of the current chapter/track.

Each time you press the button consecutively, the beginning of the previous chapter/track is located and played back.

#### Note:

Playback will not start automatically if you locate the chapter/track while a disc is pausing or not playing.



# Locating a title/chapter/track on a disc



## To locate a particular title/chapter/track directly

- For DVD: During play or pause—select a chapter  
While stopped—select a title
- For VCD: While PBC (see page 24) is not in use.

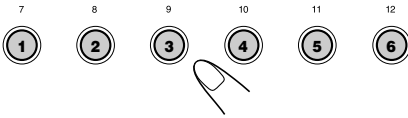

Press the number button corresponding to the title/chapter/track number to start its playback.

- To select a number from 1 – 6:  
Press 1 (7) – 6 (12) briefly.
- To select a number from 7 – 12:  
Press and hold 1 (7) – 6 (12) for more than 1 second.

### Notes:

- If you directly select the track number for a VCD with the PBC function while it is not playing, playback starts with PBC function canceled. (See page 24).
- Playback will not start automatically if you select a chapter or track during pause.

## To go to a chapter/track quickly



- For DVD: During play or pause.
- For VCD: While PBC (see page 24) is not in use.

- 1 Press MODE (M) to enter the functions mode.  
“Mode” appears on the display.



While playing a DVD:

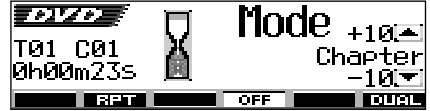

While playing a VCD or CD:

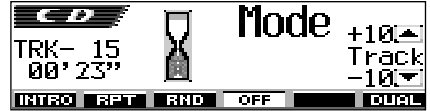

While playing an MP3 disc:



- 2 Press ▲ (up) or ▼ (down), while “Mode” is still on the display. First time you press ▲ (up) or ▼ (down), the chapter/track skips to the nearest higher or lower chapter/track with a chapter/track number of an even multiple ten (ex. 10th, 20th, 30th). Then, each time you press the button, you can skip 10 chapters/tracks (see “How to go to the desired chapter/track quickly” that follows).

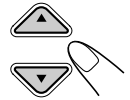

### Notes:

- For CD and VCD: If you perform this operation while a disc is not playing, playback will not start automatically.
- Except for DVD: After the last track, the first track will be selected, and vice versa.
- While playing an MP3 disc, this operation is possible only within a folder.



### How to go to the desired chapter/track quickly

• Ex. 1: To select chapter/track number 32 while playing chapter/track number 6

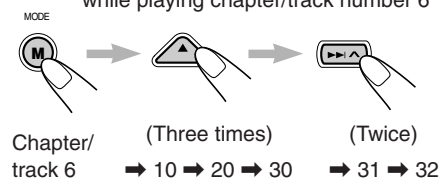

• Ex. 2: To select chapter/track number 8 while playing chapter/track number 36

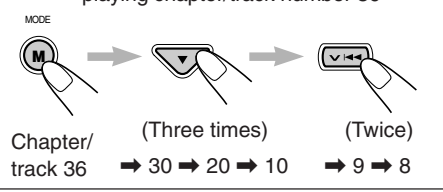

### To skip to the next or previous folder

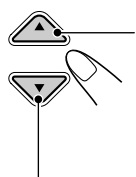

Press ▲ (up) while playing a disc to skip to the next folder. Each time you press the button consecutively, the next folder is located and the first track in the folder starts playing.

Press ▼ (down) while playing a disc to skip back to the previous folder.

Each time you press the button consecutively, the previous folder is located and the first track in the folder starts playing.

**Note:**

If the folder does not contain any MP3 tracks, it is skipped.

## Selecting a folder/track to play using the lists



You can show the folder name and track name lists on the display while playing a disc, then select the folder or track you want.

### To select a folder and start playback

**1** Press and hold ▲ (up) or ▼ (down) so that the folder name list of the inserted disc appears on the display.

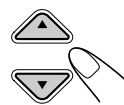

The name of the currently playing folder will be highlighted on the display.

Current folder number



**Notes:**

- The display can show only six items at a time. You can show the other items on the next lists by pressing ▲ (up) or ▼ (down).
- If you press ►/▲ or ▼ ◀/◀, the track name list of the current playing folder appears. (See the following column.)
- Only folders including MP3 tracks will be listed.

**2** Select the number (1 – 6) for the folder you want to play.

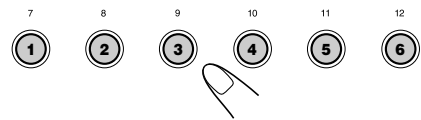



## To select a track and start playback

- 1 Press and hold ▲ (up) or ▼ (down) so that the folder name list of the inserted disc appears on the display.

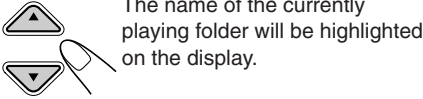

Current folder number



- 2 Press ►► ▲ or ▼ ◀◀ to show the track list of the current folder.

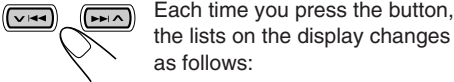

Each time you press the button, the lists on the display changes as follows:

Folder name list ↔ Track name list

Current track number

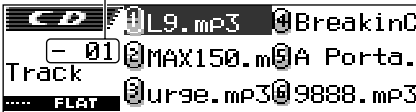

**Note:**

The display can shows only six items at a time. You can show the other items on the next lists by pressing ▲ (up) or ▼ (down).

- 3 Select the number (1 – 6) for the track you want to play.

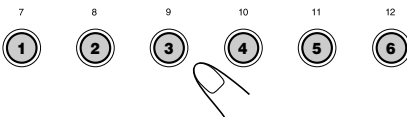

## Selecting playback modes

### Repeat Play



You can repeat a title, chapter, track, or disc.

- For DVD: During play or pause.
- For VCD: While PBC (see page 24) is not in use.

- 1 Press MODE (M) to enter the functions mode. "Mode" appears on the display.

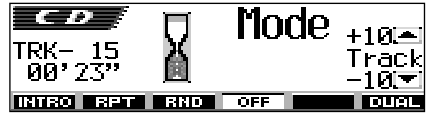

Ex. While playing a CD

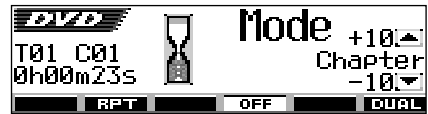

Ex. While playing a DVD

- 2 Press number button 2, while "Mode" is still on the display. Each time you press the button, repeat play mode changes as follows:

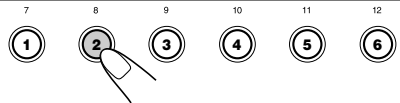

Ex. While playing a CD



• For DVD:

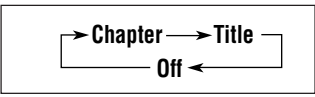

- Chapter: Current (or specified) chapter will be repeated.
  - **C-RPT** indicator appears on the display.
- Title: Current title will be repeated.
  - **T-RPT** indicator appears on the display.
- Off: Repeat Play is canceled.

**To cancel Repeat Play**, select “Repeat Off” by pressing number button 2 repeatedly or press number button 4 in step 2.

**Notes:**

- On some DVDs, Repeat Play may be canceled by the disc itself.
- On CD, VCD, and MP3 discs, Repeat Play mode cannot be turned off.
- Repeat Play mode will be canceled when you start playing back a VCD with the PBC function.

• For CD/VCD:

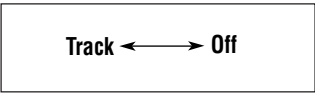

- Track: Current (or specified) track will be repeated.
  - **T-RPT** indicator appears on the display.
- Off: All the tracks in the disc will be repeated.

**Random Play**



You can play back tracks on a disc (or in a folder) at random.

- 1 Press **MODE (M)** to enter the functions mode. “Mode” appears on the display.
- 2 Press number button 3, while “Mode” is still on the display. Each time you press the button, Random Play mode changes as follows:



• For MP3:

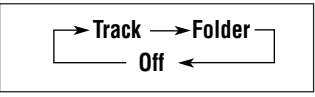

- Track: Current (or specified) track will be repeated.
  - **T-RPT** indicator appears on the display.
- Folder: All the tracks in the current (or specified) folder will be repeated.
  - **F-RPT** indicator appears on the display.
- Off: All the tracks in the disc will be repeated.

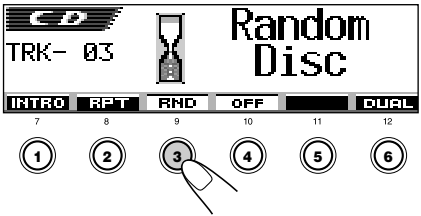

Ex. While playing a CD



• For CD:

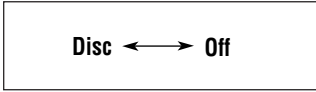

- Disc: All the tracks in the disc will be played at random.
  - **RND** indicator appears on the display.
- Off: Random Play is canceled.

• For MP3:

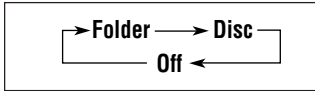

- Folder: All the tracks in the folder will be played at random, then move to the next folder and so on.
  - **RND** indicator appears on the display.
- Disc: All the tracks in the disc will be played at random.
  - **RND** indicator appears on the display.
- Off: Random Play is canceled.

To cancel Random Play, select “Random Off” by pressing number button 3 repeatedly or press number button 4 in step 2.

### Intro Scan



You can play back the first 15 seconds of each track sequentially.

- 1 Press MODE (M) to enter the functions mode. “Mode” appears on the display.



- 2 Press number button 1, while “Mode” is still on the display. Each time you press the button, Intro Scan play mode changes as follows:

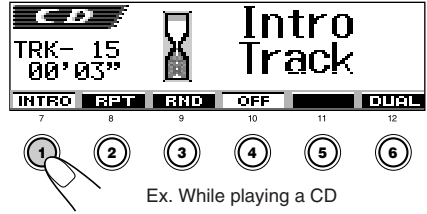

• For CD:



- Track: The beginnings of all the tracks in the disc will be played.
  - **INT** indicator appears on the display.
- Off: Intro Scan is canceled.

• For MP3:

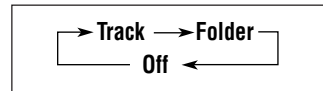

- Track: The beginnings of all the tracks in the disc will be played.
  - **INT** indicator appears on the display.
- Folder: The beginnings of the first tracks in all folders will be played.
  - **INT** indicator appears on the display.
- Off: Intro Scan is canceled.

To cancel Intro Scan, select “Intro Off” by pressing number button 1 repeatedly or press number button 4 in step 2.





## Prohibiting disc ejection

You can prohibit disc ejection and can lock a disc in the loading slot.

**While pressing SRC, press and hold  $\phi$ /I ATT for more than 2 seconds.**

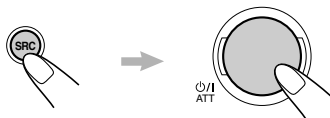

"No Eject" flashes on the display for about 5 seconds, and the disc is locked and cannot be ejected.

**To cancel the prohibition and unlock the disc**  
While pressing SRC, press  $\phi$ /I ATT again for more than 2 seconds.

"Eject OK" flashes on the display for about 5 seconds, and the disc is unlocked.



## Changing the display pattern

By pressing DISP (D), you can change the information shown on the display.

- If the information cannot be shown at a time, it will scroll on the display.  
Some characters or symbols will not be shown (will be blanked or substituted) on the display.



Each time you press the button, the display patterns change as follows:

**While playing a DVD:**

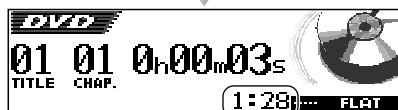
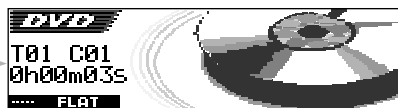

Clock time



**While playing a VCD:**

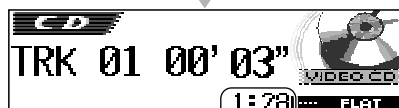
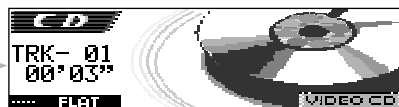

Clock time





While playing a CD Text (or CD):



While playing an MP3 disc:

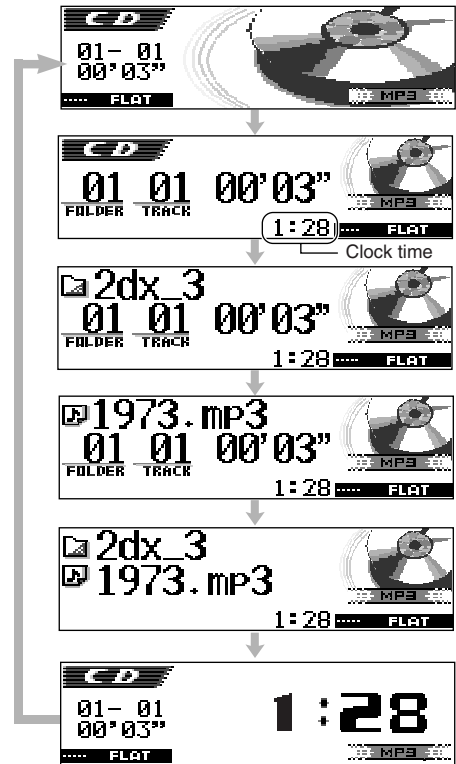

The above diagram shows examples of the display when "Tag" is set to "Off."

**Notes:**

- When the disc title/performer is shown, the (disc) indicator lights up. When the track title is shown, the (track) indicator lights up.
- If no name is assigned to the conventional CD, "NO NAME" will appear. To assign a name to a conventional CD, see page 57.
- If no disc title/performer or no track title is recorded for the CD Text, "NO NAME" will appear.

**Notes:**

- When the folder name is shown, the (folder) indicator lights up. When the file name is shown, the (file) indicator lights up.
- If "Tag" is set to "On" (see page 52), ID3 tag information will appear on the display if the disc has an ID3 tag. The (disc) indicator appears for album name/performer; while the (track) indicator appears for track title.



## Basic setting procedure

**1 Show the Setup menu (LANGUAGE menu) on the monitor.**

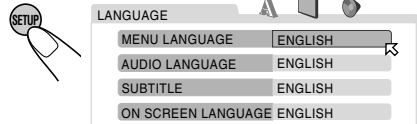

**2 Select which Setup menu screen you want to use.**

Each time you press the button, the Setup menus change as follows:

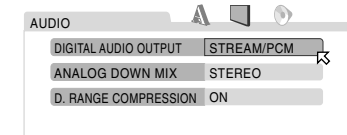

EX. When selecting the AUDIO screen

**3 Move (cursor) to an item you want to set up.**

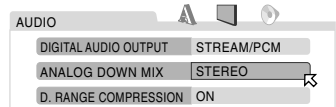

EX. When selecting ANALOG DOWN MIX

**4 Press ENTER.**



The pop-up window listing the selectable options appear on the screen.

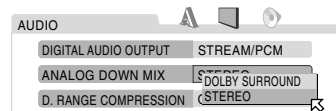

CONTINUED ON THE NEXT PAGE

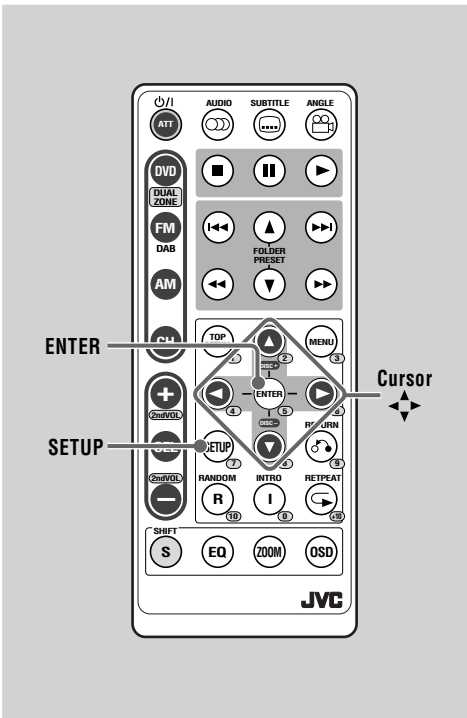

You can store the initial selection for subtitle languages, audio languages, and other settings using the Setup Menu.

- DVD Setup menu can only be displayed while a disc, except MP3 disc, is inserted and selected for the playback source.

The following operations are only possible using the remote controller, and by referring to the monitor screen.



### 5 Move (cursor) to select an option.

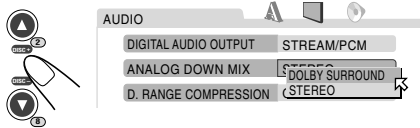

### 6 Confirm and enter your selection.

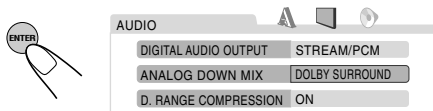

### To set other items on the same menu screen

Repeat steps 3 to 6.

### To set other items on other menu screens

Repeat steps 2 to 6.

### To return to the normal screen

Press SETUP.

## LANGUAGE

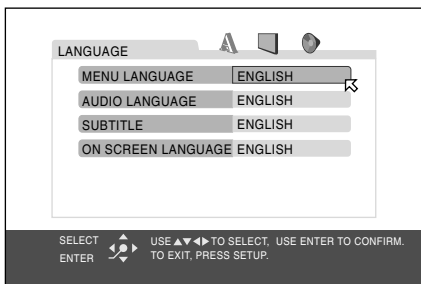

## PICTURE

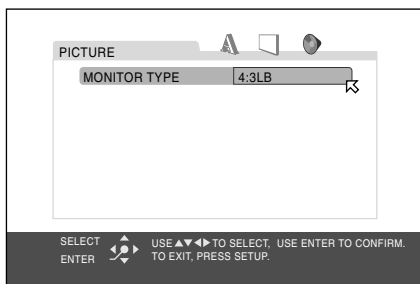

You can select the initial languages for the disc menu, audio, and subtitle.

You can also select the language for the Setup menu and some indications shown on the monitor.

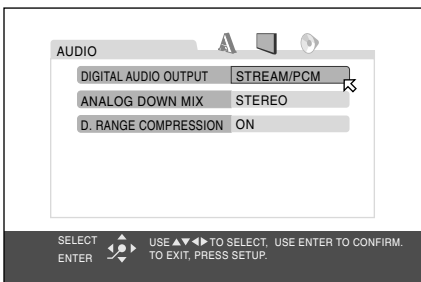

You can select the desired options concerning picture size on the monitor.

## AUDIO



You can adjust the output sounds through this unit.

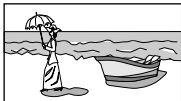

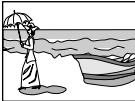
Items		For what and options
LANGUAGE	<b>MENU LANGUAGE</b> *1	Select the initial disc menu language.  ENGLISH, SPANISH, FRENCH, CHINESE, GERMAN, ITALIAN, JAPANESE, and language codes from AA to ZU (see page 67).
	<b>AUDIO LANGUAGE</b> *1	Select the initial audio language.  ENGLISH, SPANISH, FRENCH, CHINESE, GERMAN, ITALIAN, JAPANESE, and language codes from AA to ZU (see page 67).
	<b>SUBTITLE</b> *1	Select the initial subtitle language.  OFF (no subtitles), ENGLISH, SPANISH, FRENCH, CHINESE, GERMAN, ITALIAN, JAPANESE, and language codes from AA to ZU (see page 67).
	<b>ON SCREEN LANGUAGE</b>	Select the language for the Setup menu and some indications shown on the monitor.  ENGLISH, CHINESE, and SPANISH.
PICTURE	<p><b>MONITOR TYPE</b></p>  <p>16:9</p>  <p>4:3 LB</p>  <p>4:3 PS</p>	<p>Select the monitor type to watch a wide screen picture on your monitor.</p> <ul style="list-style-type: none"> <li>• <b>16:9 NORMAL</b> *2 Select this when the aspect ratio of your monitor is 16:9 and it does not have the screen size adjustment function.</li> <li>• <b>16:9 AUTO</b> Select this when the aspect ratio of your monitor is 16:9 and it has the screen size adjustment function.</li> <li>• <b>4:3 LB</b> (Letter Box) Select this when the aspect ratio of your monitor is 4:3. While viewing a wide screen picture, the black bars appear on the top and the bottom of the screen.</li> <li>• <b>4:3 PS</b> (Pan Scan) *3 Select this when the aspect ratio of your monitor is 4:3. While viewing a wide screen picture, the black bars do not appear; however, the left and right edges of the pictures will not be shown on the screen.</li> </ul>

\*1 • When the language you have selected is not recorded on a disc, the original language is automatically used as the initial language. In addition, for some discs, the initial languages settings will not work as you set due to their internal disc programming.

• While playing (or pausing), you cannot change these languages. After you change any of these language settings, eject the disc and insert it (or another disc) again so that your setting takes effect.

\*2 When you select "16:9 NORMAL" for a picture whose aspect ratio is 4:3, the picture slightly changes due to the process for converting the picture width.

\*3 Even if "4:3 PS" is selected, the screen size may become "4:3 LB" with some DVDs. This depends on how they are recorded.



Items	For what and options
<b>DIGITAL AUDIO OUTPUT</b>	<p>Select the signal format to be emitted through the DIGITAL OUT (Optical) terminal on the rear.</p> <ul style="list-style-type: none"><li>• <b>PCM ONLY</b> Select this when connecting an amplifier or a decoder incompatible with Dolby Digital and DTS, or connecting to a recording device.</li><li>• <b>DOLBY DIGITAL/PCM</b> Select this when connecting an amplifier or a decoder compatible with Dolby Digital.</li><li>• <b>STREAM/PCM</b> Select this when connecting an amplifier or a decoder compatible with Dolby Digital and DTS.</li></ul>
<b>ANALOG DOWN MIX</b>	<p>When playing back a multi-channel DVD disc, this setting affects the sounds reproduced through the analog terminals.</p> <ul style="list-style-type: none"><li>• <b>STEREO</b> Normally select this to enjoy and reproduce conventional 2-channel stereo sound from the original multi-channel sounds.</li><li>• <b>DOLBY SURROUND</b> Select this when you want to enjoy multi-channel surround audio by connecting an amplifier compatible with Dolby Surround to this receiver.</li></ul>
<b>D.RANGE COMPRESSION</b>	<p>You can enjoy a powerful sound at low or middle volume levels while playing a Dolby Digital software.</p> <ul style="list-style-type: none"><li>• <b>AUTO:</b> Select this to apply the effect to multi-channel encoded software (excluding 1 channel and 2 channel software).</li><li>• <b>ON:</b> Select this to always use this function.</li></ul>



Operations of this section are explained using the buttons on the control panel unless mentioned otherwise.

## Adjusting the sound

You can adjust the sound characteristics to your preference.

- “Vol Adj” setting is required for each source except FM. Before starting “Vol Adj,” select an appropriate source for which you want to make an adjustment.

### 1 Select the item you want to adjust.



Each time you press the button, the adjustable items change as follows:

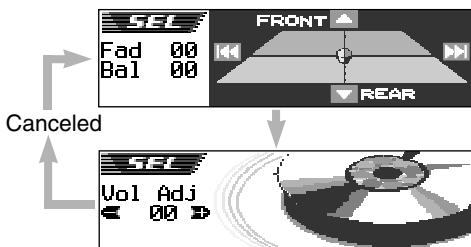
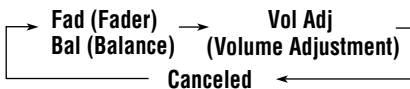

**Note:**

You can also use the SEL button on the remote controller to call up the fader/balance adjustment screen.

Indication	To do:	Range
Fad*	Adjust the front and rear speaker balance.	R06 (Rear only)   F06 (Front only)
Bal	Adjust the left and right speaker balance.	L06 (Left only)   R06 (Right only)
Vol Adj	Adjust and store the input level of each source.	-12 (min.)   +12 (max.)

\* If you are using a two-speaker system, set the fader level to “00.”

### 2 Make adjustments.

- **To adjust fader and balance—Fad, Bal:** You can make these two adjustments at the same time, by referring to the indication on the display.

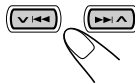

- Press ▲ (up) or ▼ (down) to adjust the fader.
- Press ►► | ▲ or ▼ | ◀◀ to adjust the balance.



**Note:**

You can also use the ►► | ▲ or ▼ | ◀◀ buttons and FOLDER PRESET ▲ (up) or FOLDER PRESET ▼ (down) on the remote controller for adjustment.

- **To adjust the input level of each source—Vol Adj:**

This setting is required for each source except FM. Before making an adjustment, select an appropriate source for which you want to make an adjustment.

Once you have made an adjustment, it is memorized, and you will not need to adjust the volume level each time you change the source.

Adjust to match the input level to the FM sound level.

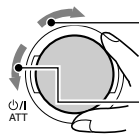

To increase the level

To decrease the level



# Selecting preset sound modes (iEQ: intelligent equalizer)

You can select a preset sound mode (iEQ: intelligent equalizer) suitable to the music genre.

- There is a time limit in doing the following procedure. If the setting is canceled before you finish, start from step 1 again.

### Available sound modes:

- |  |                                       |
|--|---------------------------------------|
| • <b>FLAT</b><br>(Flat)                  | • <b>Country</b><br>(Country music)   |
| • <b>H.ROCK</b><br>(Hard Rock)           | • <b>REGGAE</b><br>(Reggae)           |
| • <b>R &amp; B</b><br>(Rhythm and Blues) | • <b>CLASSIC</b><br>(Classical music) |
| • <b>POP</b><br>(Popular music)          | • <b>USER 1</b>                       |
| • <b>JAZZ</b><br>(Jazz music)            | • <b>USER 2</b>                       |
| • <b>DANCE</b><br>(Dance music)          | • <b>USER 3</b>                       |

## 1 Press EQ (equalizer) once.



Last selected sound mode is called up.

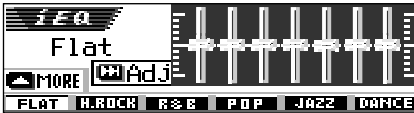

Ex.: If you have selected "Flat" previously

- If you press the button twice, the level meter selection screen appears (see page 10).

## 2 Press the number button to select the sound mode you want.

- This unit has two sound mode selection screens. To move to the other screen, press ▲ (up) or ▼ (down).

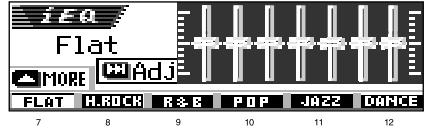

Press ▲ (up) or ▼ (down).

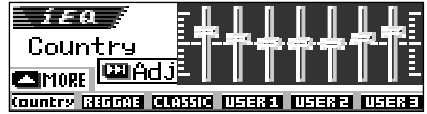

To cancel the preset sound mode, select "FLAT" in step 2.

To exit from the preset sound mode (iEQ), press EQ (equalizer) repeatedly or wait for about 5 seconds.

### Note:

For details about the preset settings of each sound mode, see page 66.





# Storing your own sound adjustments

You can adjust the sound modes to your preference and store your own adjustments in memory (User 1, User 2, and User 3).

- There is a time limit in doing the following procedure. If the setting is canceled before you finish, start from step 1 again.

## 1 Press EQ (equalizer) once.

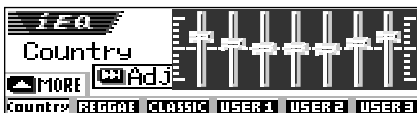

Ex.: When you have selected "Country" previously

- If you press the button twice, the level meter selection screen appears (see page 10).

## 2 Select the sound mode you want to adjust.

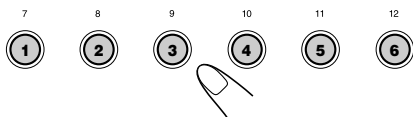

- This unit has two sound mode selection screens. To move to the other screen, press ▲ (up) or ▼ (down).

## 3 Enter the sound adjustment mode.

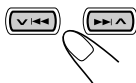

The following sound mode adjustment screen appears on the display.

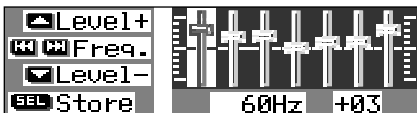

## 4 Make adjustments as you like.

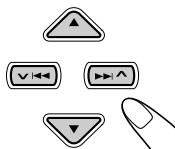

- 1) Press ►►, ▲ or ▼◄◄ to select the frequency band—60Hz, 150Hz, 400Hz, 1kHz, 2.4kHz, 6kHz, 12kHz.

- 2) Press ▲ (up) or ▼ (down) to adjust the level of the selected band within the range of -05 to +05.

- 3) Repeat steps 1) and 2) to adjust the other frequency bands.

## 5 Store the adjustment you made.



The confirmation message appears—whether you want to store the adjustment.

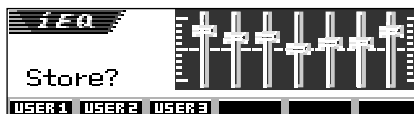

If you want to cancel the adjustments, press EQ (equalizer).

- Adjustment you made remains effective until you select another sound mode.

## 6 Select one of the user sound modes (User 1, User 2, or User 3) you want to store into.

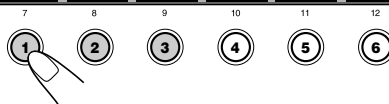
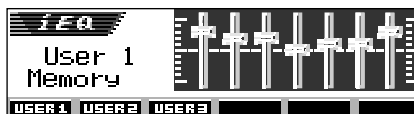

Ex.: When you select "User 1"



# OTHER MAIN FUNCTIONS

Operations of this section are explained using the buttons on the control panel unless mentioned otherwise.

## Changing the general settings (PSM)

You can change the items listed in the table on page 51 by using the PSM (Preferred Setting Mode) control.

- The PSM items are grouped into five categories—MOVIE, CLOCK, DISP (display), AUDIO, and COLOR.

### Basic Procedure

Ex. To change "Contrast"

- 1** Press and hold SEL (select) for more than 2 seconds so that one of the PSM items appears on the display.



- 2** Press number button (in this example, 3) to select one of the PSM categories.

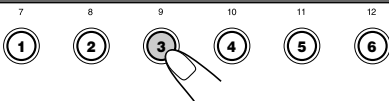

The first-listed item in the selected category appears.

- 3** Select the PSM item you want to adjust.

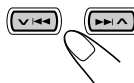

- By pressing  $\blacktriangleright\blacktriangle$   $\blacktriangle$  or  $\blacktriangleleft$   $\blacktriangleleft$  repeatedly, you can also move to other categories.

- 4** Adjust the PSM item selected.

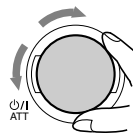

- 5** Repeat steps 2 to 4 to adjust the other PSM items if necessary.

- 6** Finish the setting.





Preferred Setting Mode (PSM) items

		Indications	Selectable values/items		Factory-preset settings	See page
MOVIE	<b>Graphics</b>	Movie demonstration	All Demo ↔ Int Demo ↕ Off ↕		Int Demo	9, 52
	<b>KeyIn CFM</b>	Key in confirmation	Long ↔ Short ↕ Off ↕		Long	52
CLOCK	<b>Clock Hr</b>	Hour adjustment	1 – 12 (0 – 23)		1 (1:00)	9
	<b>Clock Min</b>	Minute adjustment	00 – 59		00 (1:00)	9
	<b>24H/12H</b>	24 hours or 12 hours	12Hours	24Hours	12Hours	10
DISP (display)	<b>Scroll</b>	Scroll mode	Once ↔ Auto ↕ Off ↕		Once	52
	<b>Dimmer</b>	Dimmer mode	↔ Auto ↔ Off ↕ ↕ Time Set ↔ On ↕		Auto	54
	<b>From–To<sup>*1</sup></b>	Dimmer time setting	Any time – Any time		6PM – 7AM	54
	<b>Contrast</b>	Contrast	1 – 10		5	52
	<b>LCD Type</b>	Display type	Positive ↔ Negative ↕ Auto ↕		Auto	52
	<b>Font Type</b>	Font type	1	2	1	52
	<b>Tag</b>	Tag display	Off	On	On	52
	<b>NTSC/PAL</b>	Video system	NTSC	PAL	PAL	53
AUDIO	<b>Beep</b>	Key-touch tone	Off	On	On	53
	<b>Ext Input<sup>*2</sup></b>	External component	Changer	Line In	Changer	53
	<b>Rear SPK</b>	Rear speaker output	Off	On	On	31
	<b>Telephone</b>	Telephone muting	Muting1 ↔ Muting2 ↕ Off ↕		Off	53
COLOR	<b>All SRC</b>	Selected source	See page 55 for details		Every	55
	<b>User</b>	User color selection	Day	Night	Day	56
	<b>R</b>	Red	00 – 11		Day: 07/Night: 05	56
	<b>G</b>	Green	00 – 11		Day: 07/Night: 05	56
	<b>B</b>	Blue	00 – 11		Day: 07/Night: 05	56

\*1 Displayed only when “Dimmer” is set to “Time Set.”

\*2 Displayed only when one of the following sources is selected—FM, AM, and CD.



## To set the movie demonstration—Graphics

When shipped from the factory, the movie has been activated.

- All Demo: If no operation is done for about 20 seconds, the movie demonstration starts automatically.
- Int Demo: If no operation is done for about 20 seconds, the movie demonstration and playback source indication appears alternately on the display.
- Off: Cancels the movie demonstration.

## To select the source animation on the display—KeyIn CFM

When changing the source, the display shows the source animation. You can select the source animation on the display according to your preference.

- Long: A long source animation appears.
- Short: A short source animation appears.
- Off: Cancels the source animation.

## To select the scroll mode—Scroll

You can select the scroll mode for the disc information (when the entire text cannot be shown at once).

- Once: Scrolls only once.
- Auto: Repeats the scroll (in 5-second intervals).
- Off: Cancels scroll mode.

### **Note:**

*Even if the scroll mode is set to “Off,” you can scroll the display by pressing DISP (D) for more than one second.*

## To adjust the display contrast level—Contrast

You can adjust the display contrast level among 1 to 10.

Adjust it to make the display indications clear and legible.

## To select the display illumination pattern—LCD Type

You can select the display illumination patterns according to your preference.

- Auto: Positive pattern will be selected during the day time (depending on the “Dimmer” setting); on the other hand, negative pattern will be used during the night time (depending on the “Dimmer” setting).
- Positive: Positive (normal) pattern of the display.
- Negative: Negative pattern of the display.

## To select the font on the display—Font Type

You can change the font types used on the display. Select either “1” or “2” according to your preference.

## To turn the tag display on or off—Tag

An MP3 file can contain file information called “ID3 Tag” where its album name, performer, track title, etc. are recorded.

There are two versions—ID3v1 (ID3 Tag version 1) and ID3v2 (ID3 Tag version 2). Only ID3v1 can be shown.

- On: Turns on the ID3 tag display while playing MP3 files.
  - If an MP3 file does not have ID3 tags, folder name and file name appear.

### **Note:**

*If you change the setting from “Off” to “On” while playing an MP3 file, the tag display will be activated when the next file starts playing.*

- Off: Turns off the ID3 tag display while playing MP3 files. (Only the folder name and file name can be shown.)



## To select a proper video system —NTSC/PAL

Select the appropriate video system to match it to the connected monitor.

- **NTSC:** Select when connecting an NTSC monitor.
- **PAL:** Select when connecting a PAL monitor.

## To turn on/off the key-touch tone—Beep

You can deactivate the key-touch tone if you do not want it to beep each time you press a button.

- **On:** Activates the key-touch tone.
- **Off:** Deactivates the key-touch tone.

## To select the external component to use —Ext Input

You can connect an external component to the CD changer jack on the rear using the Line Input Adapter KS-U57 (not supplied).

To use the external component as the playback source through this unit, you need to select which component—CD changer or external component—to use.

- **Changer:** To use the CD changer.
- **Line In:** To use the external component other than CD changer.

**Note:**

*For connecting the Line Input Adapter KS-U57 and the external component, refer to the Installation/Connection Manual (separate volume).*

## To select the telephone muting— Telephone

This mode is used when a cellular phone system is connected. Depending on the phone system used, select either “Muting1” or “Muting2,” whichever mutes the sounds from this unit.

- **Muting1:** Selects this if this setting can mute the sounds when using the cellular phone.
- **Muting2:** Selects this if this setting can mute the sounds when using the cellular phone.
- **Off:** Cancels the telephone muting.

You can use the following table to keep memo of your own PSM settings.

MOVIE	Graphics			
	KeyIn CFM			
CLOCK	Clock Hr			
	Clock Min			
	24H/12H			
DISP (display)	Scroll			
	Dimmer			
	From- To			
	Contrast			
	LCD Type			
	Font Type			
	Tag			
AUDIO	NTSC/PAL			
	Beep			
	Rear SPK			
	Ext Input			
COLOR	Telephone			
	All SRC			
	CD			
	Changer			
	Line in			
	FM			
	AM			
	User Day	R	G	B
User Night	R	G	B	



## Selecting the dimmer mode

You can dim the display at night automatically or as you set the timer. When shipped from the factory, Auto Dimmer mode is activated.

**Note:**

Auto Dimmer supplied with this unit may not work correctly on some vehicles, particularly on those having a control dial for dimming. In this case, select any setting other than "Auto."

**1** Press and hold SEL (select) for more than 2 seconds so that one of the PSM items appears on the display. (PSM: See pages 51.)



**2** Press number button 3 to select "DISP"—Display category of the PSM settings.

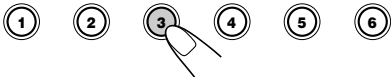

**3** Press >>> ^ or v <<< to select "Dimmer."



**4** Set the dimmer mode to your preference.

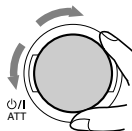

- Auto: Activates Auto Dimmer. When you turn on the car head lights, the display automatically dims.
- Off: Cancels Auto Dimmer.
- On: Always dims the display.
- Time Set: Used to set the timer for the dimmer function.

**Note:**

Selecting "Auto" or "Time Set" may change the display pattern to the "Negative" or "Positive" pattern if "LCD Type" is set to "Auto."

- If you select "Time Set," go to the following steps to set the timer.
- If you select any setting other than "Time Set," go to step 7 to finish the setting.

**5** Select "From-To" to set the timer for the dimmer mode.



**6** Set the timer.

- 1 Turn the control dial to select the start time.
- 2 Press >>> ^ once.
- 3 Turn the control dial to select the end time.

**7** Finish the setting.





# Changing the display color

You can set the display color using the PSM control. You can select your favorite color for each source (or for all sources). You can also create your own colors, and set them as the display color.

## Setting the desired color for each source

Once you have set the color for each source (or for all sources), the display illuminates in the selected color when the source is selected.

- 1 Press and hold SEL (select) for more than 2 seconds so that one of the PSM items appears on the display.** (PSM: See pages 51.)



- 2 Press number button 6 to select "COLOR"—Color category of the PSM settings.**

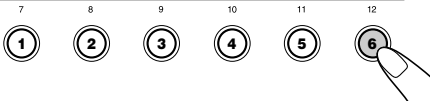

The "All SRC" setting screen appears on the display.

- 3 Select the source—All SRC, CD, Changer (Line), FM, or AM—that you want to set the display color for.**

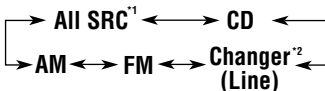
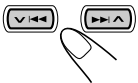

\*1 When you select "All SRC," the same color will be used for all sources.  
 \*2 Either component which is selected in the "Ext Input" setting appears.

- 4 Select the display color.**

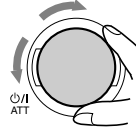

As you turn the control dial, the colors change as follows:

Every\*<sup>1</sup> ↔ Aqua ↔ Sky ↔ Sea ↔  
 Leaves ↔ Grass ↔ Red ↔ Rose ↔  
 Amber ↔ Honey ↔ Violet ↔ Cotton ↔  
 Snow ↔ User\*<sup>2</sup> ↔ (back to the beginning)

\*1 When you select "Every," the color changes every 2 seconds (changing to every color listed above except "User").  
 \*2 When you select "User," the user-edited colors—"Day" and "Night" will be applied. (See page 56.)

- 5 Repeat steps 3 and 4 to select the color for each source (except when selecting "All SRC" in step 3).**

- If you want to apply different colors to the different sources, select any source other than "All SRC" before finish the setting.

- 6 Finish the setting.**





### Creating your own color—User

You can create your own colors—"Day" and "Night," and select them as the display color for any desired source.

- Day: Can be used as your user color during the day time (while the headlights are turned off), or as set by the timer—"From - To."
- Night: Can be used as your user color during the night time (while the headlights are turned on), or as set by the timer—"From - To."

**1** Press and hold SEL (select) for more than 2 seconds so that one of the PSM items appears on the display. (PSM: See pages 51.)



**2** Press number button 6 to select "COLOR"—Color category of the PSM settings.



The source/color selecting screen appears on the display.

**3** Select "User" as a color.

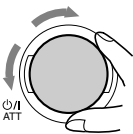

The user color will be applied to the currently selected source (the one shown on the upper portion of the display. In this example "All SRC").

To select which source to apply your user color to, select the target source first by pressing ▲ (up) or ▼ (down), before selecting "User" in this step.

**4** Select the user color adjustment screen.

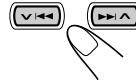

One of the user color adjustment screens appears. "User Day" or "User Night" is shown on the left side of the display.

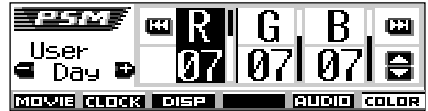

**5** Select either "Day" or "Night" to make an adjustment for.

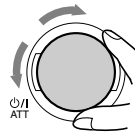

**6** Adjust the selected user color.

1) Press ►► | ▲ or ▼ | ◀◀ to select one of three primary colors—"R" (red), "G" (green), and "B" (blue).



2) Press ▲ (up) or ▼ (down) to adjust the selected primary color.

You can adjust within the range of 00 to 11.

3) Repeat steps 1) and 2) to adjust the other primary colors.

**7** Repeat steps 5 and 6 to adjust the other user colors—"Day" or "Night."

**8** Finish the setting.







# Assigning names to the sources

You can assign names to station frequencies, CDs (both in this unit and in the CD changer), and the external component. After assigning a name, it will appear on the display when you select the source.

Sources	Maximum number of characters
Station frequencies	Up to 10 characters (up to 30 station frequencies including both FM and AM)
CDs*	Up to 32 characters (up to 40 discs)
External component	Up to 8 characters

\* You can assign a name only to conventional CDs.

## 1 Select a source you want to assign a name to.

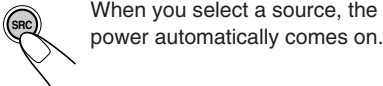

## 2 While pressing DISP (D), press and hold SEL (select) for more than 2 seconds.



Ex.: When you select "DISC" as the source

## 3 Select the character set you want while the first character position is flashing.

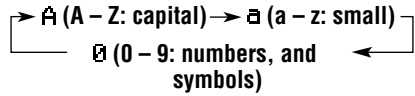
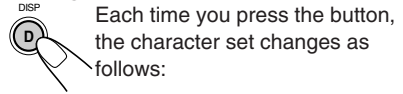

## 4 Select a character.

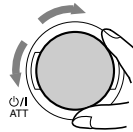

- About the available characters, see page 66.

## 5 Move the cursor to the next (or previous) character position.

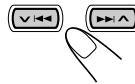

## 6 Repeat steps 3 to 5 until you finish entering the name.

## 7 Finish the procedure while the last selected character is flashing.



## To erase entered characters

Insert spaces using the same procedure described above.

### Notes:

- When you try to assign a name to the 41st disc or to the 31st station frequency, "Name Full" appears and you cannot enter the text entry mode. In this case, delete unwanted names before assignment.
- When the CD changer is connected, you can assign names to CDs in the CD changer. These names can also be shown on the display if you insert the CDs in this unit.



## Detaching the control panel

You can detach the control panel when leaving the car.

When detaching or attaching the control panel, be careful not to damage the connectors on the back of the control panel and on the panel holder.

### Detaching the control panel

Before detaching the control panel, be sure to turn off the power.

- 1** Unlock the control panel.

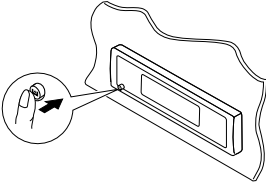

- 2** Pull the control panel out of the unit.

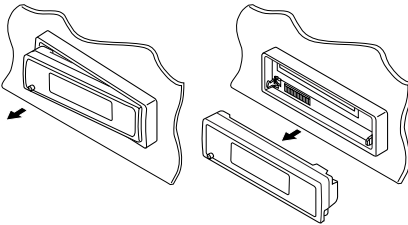

- 3** Put the detached control panel into the provided case.

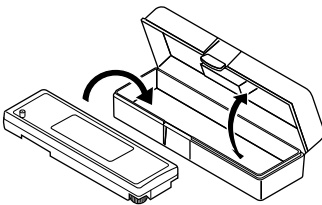

## Attaching the control panel

- 1** Insert the right side of the control panel into the groove on the panel holder.

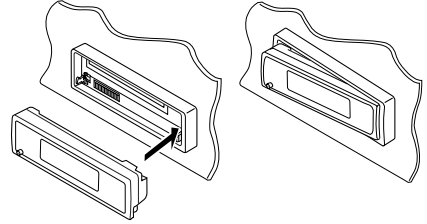

- 2** Press the left side of the control panel to fix it to the panel holder.

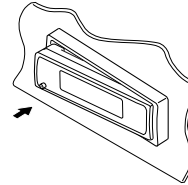

### Note on cleaning the connectors:

*If you frequently detach the control panel, the connectors will deteriorate.*

*To minimize this possibility, periodically wipe the connectors with a cotton swab or cloth moistened with alcohol, being careful not to damage the connectors.*

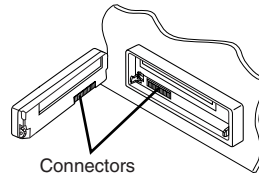

# CD CHANGER OPERATIONS

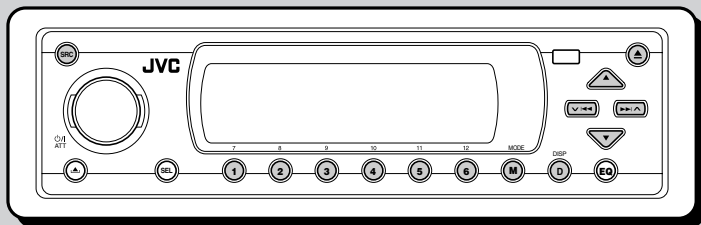
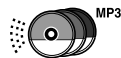

Operations of this section are explained using the buttons on the control panel unless mentioned otherwise.

We recommend that you use the JVC MP3-compatible CD changer with your unit.

By using this CD changer, you can play back your original CD-Rs (Recordable) and CD-RWs (Rewritable) recorded either in audio CD format or in MP3 format.

- You can also connect other CH-X series CD changers (except CH-X99 and CH-X100). However, they are not compatible with MP3 discs, so you cannot play back MP3 discs.
- You cannot use the KD-MK series CD changers with this unit.

Before operating your CD changer:

- Refer also to the Instructions supplied with your CD changer.
- If no discs are in the magazine of the CD changer or the discs are inserted upside down, “No Disc” will flash on the display. If this happens, remove the magazine and position the discs correctly.
- If no magazine is loaded in the CD changer, “No Magazine” flashes on the display. If this happens, insert the magazine in the CD changer.
- If “Reset 1” – “Reset 8” flashes on the display, something is wrong with the connection between this unit and the CD changer. If this happens, check the connection and make sure the cords are connected firmly. Then, press the reset button of the CD changer.

**Note:**

You cannot play back a DVD and a VCD on the CD changer.

## Playing discs

### Select the CD changer (CD-CH).



Each time you press the button, the source changes as described on page 8. When you select a source, the power automatically comes on.

**Notes:**

- You can also use the CH button on the remote controller.
- If you have changed the “Ext Input” setting to “Line In” (see page 53), you cannot select the CD changer.

### When the current disc is an MP3 disc:

Playback starts from the first folder of the current disc once file check is completed.

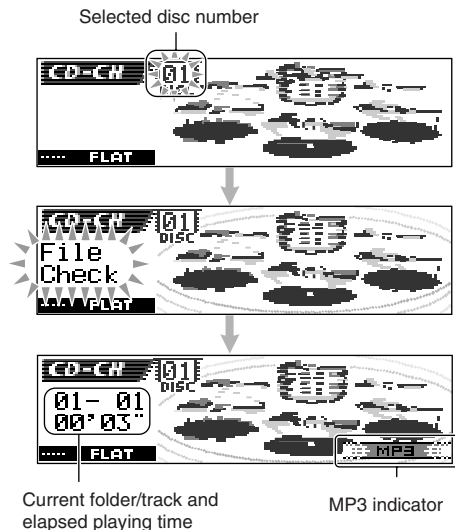

- **When the current disc is a CD:**  
Playback starts from the first track of the current disc.

Selected disc number

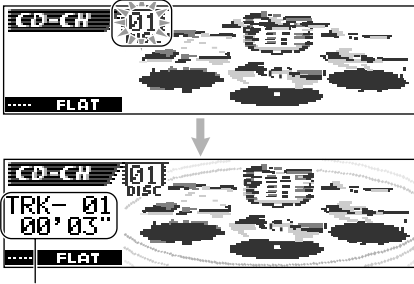

Current track and elapsed playing time

**Note:**

If you change the source, CD changer play also stops. Next time you select the CD changer as the source, CD changer play starts from where playback has been stopped previously.

**To change the display information**

While playing back a disc, you can change the disc information shown on the display.



Press DISP (D) repeatedly. Each time you press the button, the display changes.

- For details, see pages 41 and 42.

**To go to a particular disc directly**

Press the number button corresponding to the disc number to start its playback (while the CD changer is playing).

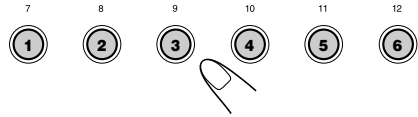

- To select a disc number from 1 – 6:  
Press 1 (7) – 6 (12) briefly.
- To select a disc number from 7 – 12:  
Press and hold 1 (7) – 6 (12) for more than one second.

**Note:**

You can also use the DISC +/- buttons on the remote controller to select a disc.

**To fast-forward or reverse the track**

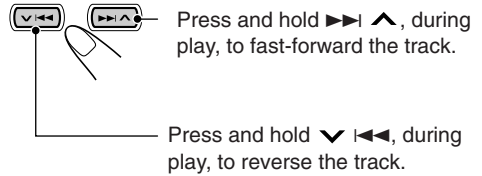

**Note:**

During this operation on an MP3 disc, you can only hear intermittent sounds. (The elapsed playing time also changes intermittently on the display.)

**To go to the next or previous tracks**

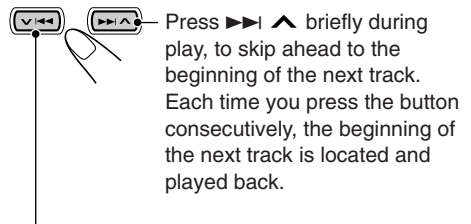

Press v I<<< briefly during play, to skip back to the beginning of the current track. Each time you press the button consecutively, the beginning of the previous track is located and played back.

This operation is only possible when using JVC MP3-compatible CD changer (CH-X1500).

## To go to a track quickly

- 1 Press MODE (M) to enter the functions mode while playing a disc.

"Mode" appears on the display.



- 2 Press ▲ (up) or ▼ (down).

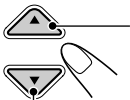

To skip 10 tracks\* forward to the last track

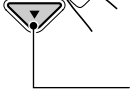

To skip 10 tracks\* backward to the first track

- \* The first time you press ▲ (up) or ▼ (down) button, the track skips to the nearest higher or lower track with a track number of an even multiple ten (ex. 10th, 20th, 30th).

Then each time you press the button, you can skip 10 tracks (see "How to go to the desired track quickly" on the right column).

### Notes:

- After the last track, the first track will be selected, and vice versa.
- If the current playing disc is an MP3 disc, tracks are skipped within the same folder.

## How to go to the desired track quickly

- Ex. 1: To select track number 32 while playing track number 6

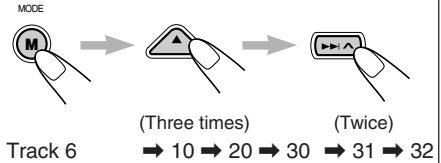

- Ex. 2: To select track number 8 while playing track number 36

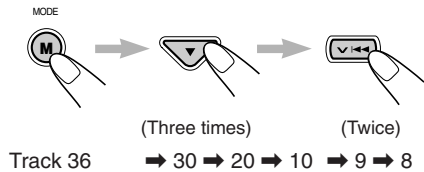

## To skip to the next or previous folder (only for MP3 discs)



Press ▲ (up) while playing an MP3 disc, to go to the next folder.

Each time you press the button consecutively, the next folder is located, and the first track in the folder starts playback.

Press ▼ (down) while playing an MP3 disc, to go to the previous folder.

Each time you press the button consecutively, the previous folder is located, and the first track in the folder starts playback.

### Note:

If the folder does not contain any MP3 tracks, it is skipped.

## To select a disc using the disc lists

If you forget what discs are loaded in the CD changer, you can show the disc title list and select a disc in the list shown on the display.

- The display can show only six disc names at a time.

- 1 While playing a disc, press and hold ▲ (up) or ▼ (down) until a disc name list appears on the display.

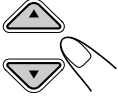

Selected disc number

**Note:**

If a disc has a disc title (CD Text) or an assigned disc name, it will be shown on the display. However, if the disc has not been played before, its disc number will appear.

- 2 Press ▲ (up) or ▼ (down) to show the other disc name list, if necessary.

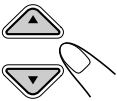

- 3 Select the number (1 – 6) for the disc you want to play.

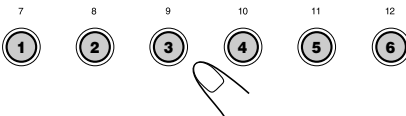

While playing an MP3 disc, you can also show the folder list(s) and track list(s) on the display, then select a folder or track.

- 1 While playing an MP3 disc, press and hold ▲ (up) or ▼ (down) until a disc name list appears on the display.

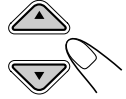

- 2 Press ►► ▲ or ▼ ◀◀ to show a folder list of the current disc or track list of the current folder.

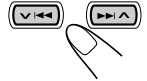

Each time you press the button, lists on the display changes as follows:



Current folder number



Ex.: When folder list is selected

Current track number

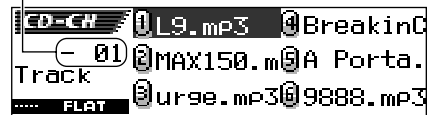

Ex.: When track list is selected

**Note:**

The display can show only six items at a time. You can show the other items on the next lists by pressing ▲ (up) or ▼ (down).

- 3 Press the number button for the disc, folder, or track you want to play.

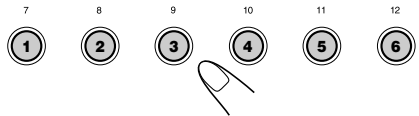

# Selecting the playback modes

## To play back tracks repeatedly (Repeat Play)

From the remote controller:



Press REPEAT (↻) repeatedly until the Repeat Play mode you want is selected.

On the control panel:

1 Press MODE (M) to enter the functions mode during play. "Mode" appears on the display.



2 Press number button 2 repeatedly while "Mode" is still on the display. Each time you press the button, Repeat Play mode changes as follows:



For MP3 discs:

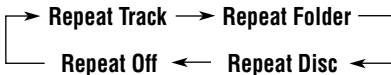



For CDs:



**Note:**

MP3 indicator also lights up if the current playing disc is an MP3 disc.

Mode	Active indicator	Plays repeatedly
Repeat Track	 RPT indicator lights up.	The current (or specified) track.
Repeat Folder*	 RPT indicator lights up.	All tracks of the current (or specified) folder of the current disc.
Repeat Disc	 RPT indicator lights up.	All tracks of the current (or specified) disc.

\* "Repeat Folder" is only applicable for MP3 disc.

To cancel Repeat Play, select "Repeat Off" by pressing number button 2 repeatedly or press number button 4 in step 2.

## To play back tracks at random (Random Play)

From the remote controller:



Press RANDOM (R) repeatedly until the Random Play mode you want is selected.

On the control panel:

1 Press MODE (M) to enter the functions mode during play. "Mode" appears on the display.



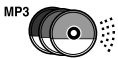

2 Press number button 3 repeatedly while “Mode” is still on the display. Each time you press the button, Random Play mode changes as follows:



For MP3 discs:

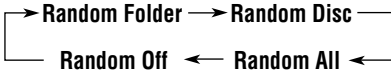

For CDs:



**Note:**

MP3 indicator also lights up if the current playing disc is an MP3 disc.

Mode	Active indicator	Plays at random
Random Folder*	<b>RND</b> indicator lights up.	All tracks of the current folder, then tracks of the next folder and so on.
Random Disc	<b>RND</b> indicator lights up.	All tracks of the current (or specified) disc.
Random All	<b>ALL RND</b> indicator lights up.	All tracks of all discs inserted in the magazine.

\* “Random Folder” is only applicable for MP3 disc.

To cancel Random Play, select “Random Off” by pressing number button 3 repeatedly or press number button 4 in step 2.

**To play back only intros (Intro Scan)**

From the remote controller:



Press INTRO (I) repeatedly until the Intro Scan mode you want is selected.

On the control panel:

1 Press MODE (M) to enter the functions mode during play. “Mode” appears on the display.



2 Press number button 1 repeatedly while “Mode” is still on the display. Each time you press the button, Intro Scan mode changes as follows:

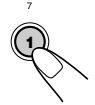

For MP3 discs:



For CDs:



**Note:**

MP3 indicator also lights up if the current playing disc is an MP3 disc.

Mode	Active indicator	Plays the beginnings (15 seconds) of
Intro Track	<b>INT</b> indicator lights up.	All tracks of the current disc.
Intro Folder*	<b>INT</b> indicator lights up.	The first track of every folder of the current disc.
Intro Disc	<b>INT</b> indicator lights up.	The first tracks of the inserted discs.

\* “Intro Folder” is only applicable for MP3 disc.

To cancel Intro Scan, select “Intro Off” by pressing number button 1 repeatedly or press number button 4 in step 2.



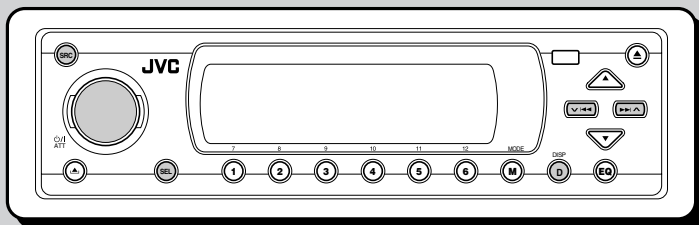

Operations of this section are explained using the buttons on the control panel unless mentioned otherwise.

## Playing an external component

You can connect the external component to the CD changer jack on the rear using the Line Input Adapter KS-U57 (not supplied).

### Preparation:

For connecting the Line Input Adapter KS-U57 and the external component, refer to the Installation/Connection Manual (separate volume).

**Before operating the external component,** select the correct external input correctly by following the procedure below.

- See also “Changing the general settings (PSM)” on page 50.

- 1 Press and hold SEL (select) for more than 2 seconds so that one of the PSM items appears on the display.
- 2 Press number button 5 to select “AUDIO”—Audio category of the PSM settings.
- 3 Press  $\blacktriangleright$   $\blacktriangle$  or  $\blacktriangleright$   $\blacktriangledown$  to select “Ext Input”\*.
- 4 Turn the control dial clockwise to select “Line In.”
- 5 Press SEL (select) to finish the setting.

- For details, see “To select the external component to use—Ext Input” on page 53.

\* Displayed only when one of the following sources is selected—FM, AM, and CD.

## 1 Select the external component (LINE IN).



Each time you press the button, the source changes as described on page 8. When you select a source, the power automatically comes on.

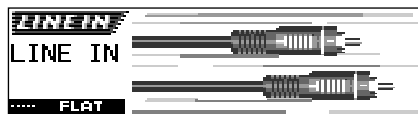

\* Displayed only when one of the following sources is selected—FM, AM, and CD.

## 2 Turn on the connected component and start playing the source.

## 3 Adjust the volume.

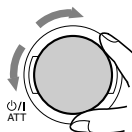

## 4 Adjust the sound characteristics you want. (See pages 47 – 49.)

### Note:

You can also change the display pattern by pressing DISP (D) repeatedly.



# ADDITIONAL INFORMATION

## Sound modes (preset frequency level settings)

The list below shows the preset frequency level settings for each sound mode.

- You can adjust the preset sound modes temporarily. However, your temporary adjustments will be reset when you select another sound mode.

Sound Mode	Preset equalizing values						
	60 Hz	150 Hz	400 Hz	1 kHz	2.4 kHz	6 kHz	12 kHz
Flat	00	00	00	00	00	00	00
Hard Rock	+03	+03	+01	00	00	+02	+01
R & B	+03	+02	+02	00	+01	+01	+03
Pop	00	+02	00	00	+01	+01	+02
Jazz	+03	+02	+01	+01	+01	+03	+02
Dance Music	+04	+02	00	-02	-01	+01	+01
Country	+02	+01	00	00	00	+01	+02
Reggae	+03	00	00	+01	+02	+02	+03
Classic	+02	+03	+01	00	00	+02	00
User 1	00	00	00	00	00	00	00
User 2	00	00	00	00	00	00	00
User 3	00	00	00	00	00	00	00

## Available characters

You can use the following characters to assign names to stations, CDs, and external component. (See page 57.)

### Capital letters

A	B	C	D	E
F	G	H	I	J
K	L	M	N	O
P	Q	R	S	T
U	V	W	X	Y
Z	space			

### Small letters

a	b	c	d	e
f	g	h	i	j
k	l	m	n	o
p	q	r	s	t
u	v	w	x	y
z	space			

### Numbers and symbols

0	1	2	3	4
5	6	7	8	9
!	"	#	\$	%
&	'	(	)	*
+	,	-	.	/
:	;	<	=	>
?	@	_	`	space

# LANGUAGE CODES



Code	Language	Code	Language	Code	Language
AA	Afar	KA	Georgian	SN	Shona
AB	Abkhazian	KK	Kazakh	SO	Somali
AF	Afrikaans	KL	Greenlandic	SQ	Albanian
AM	Ameharic	KM	Cambodian	SR	Serbian
AR	Arabic	KN	Kannada	SS	Siswati
AS	Assamese	KO	Korean (KOR)	ST	Sesotho
AY	Aymara	KS	Kashmiri	SU	Sundanese
AZ	Azerbaijani	KU	Kurdish	SV	Swedish
BA	Bashkir	KY	Kirghiz	SW	Swahili
BE	Byelorussian	LA	Latin	TA	Tamil
BG	Bulgarian	LN	Lingala	TE	Telugu
BH	Bihari	LO	Laothian	TG	Tajik
BI	Bislama	LT	Lithuanian	TH	Thai
BN	Bengali, Bangla	LV	Latvian, Lettish	TI	Tigrinya
BO	Tibetan	MG	Malagasy	TK	Turkmen
BR	Breton	MI	Maori	TL	Tagalog
CA	Catalan	MK	Macedonian	TN	Setswana
CO	Corsican	ML	Malayalam	TO	Tonga
CS	Czech	MN	Mongolian	TR	Turkish
CY	Welsh	MO	Moldavian	TS	Tsonga
DA	Danish	MR	Marathi	TT	Tatar
DZ	Bhutani	MS	Malay (MAY)	TW	Twi
EL	Greek	MT	Maltese	UK	Ukrainian
EO	Esperanto	MY	Burmese	UR	Urdu
ET	Estonian	NA	Nauru	UZ	Uzbek
EU	Basque	NE	Nepali	VI	Vietnamese
FA	Persian	NL	Dutch	VO	Volapuk
FI	Finnish	NO	Norwegian	WO	Wolof
FJ	Fiji	OC	Occitan	XH	Xhosa
FO	Faroese	OM	(Afan) Oromo	YO	Yoruba
FY	Frisian	OR	Oriya	ZU	Zulu
GA	Irish	PA	Panjabi		
GD	Scots Gaelic	PL	Polish		
GL	Galician	PS	Pashto, Pushto		
GN	Guarani	PT	Portuguese		
GU	Gujarati	QU	Quechua		
HA	Hausa	RM	Rhaeto-Romance		
HI	Hindi	RN	Kirundi		
HR	Croatian	RO	Rumanian		
HU	Hungarian	RU	Russian		
HY	Armenian	RW	Kinyarwanda		
IA	Interlingua	SA	Sanskrit		
IE	Interlingue	SD	Sindhi		
IK	Inupiak	SG	Sangho		
IN	Indonesian	SH	Serbo-Croatian		
IS	Icelandic	SI	Singhalese		
IW	Hebrew	SK	Slovak		
JI	Yiddish	SL	Slovenian		
JW	Javanese	SM	Samoan		



## 4:3 Letterbox Screen

This is one method for displaying a wide screen picture on a conventional sized (4:3) TV. While viewing a wide screen picture, the black bars appear on the top and the bottom of the screen.



## 4:3 Pan-Scan Screen

This is one method for displaying a wide screen picture on a conventional sized (4:3) TV. While viewing a wide screen picture, the left and right edges of the pictures will not be shown on the screen.

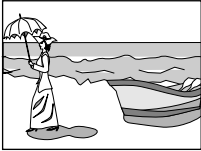

## Dolby Digital

Dolby Digital is a technology developed by Dolby Laboratories that reproduces multi-channel cinema sound in systems equipped with a Dolby Digital multi-channel processor or amplifier. Dolby Digital can deliver from mono up to 5.1 discrete channels of excellent sound quality.

The KD-DV5000 automatically recognizes the Dolby Digital bitstream and provides a downmix suitable for two-channel listening. An additional Dolby Digital decoder or amplifier is required to reproduce the discrete multi-channel sound encoded in many DVDs.

## DTS Digital Surround

This is another discrete 5.1 channel digital audio format, available on CD, LD, and DVD software, developed by Digital Theater Systems, Inc. Compared to Dolby Digital, the audio compression rate is relatively low. This fact allows DTS Digital Surround format to add breadth and depth to the reproduced sounds. As a result, DTS Digital Surround features natural, solid and clear sound.

To reproduce these surround signals, you need to connect an amplifier or a decoder compatible with DTS Digital Surround.

## ID3 Tag (MP3)

An MP3 file can contain file information called "ID3 Tag" where its album name, performer, track title, etc. are recorded.

There are two versions—ID3v1 (ID3 Tag version 1) and ID3v2 (ID3 Tag version 2). Only ID3v1 can be shown.

## Linear PCM

This is a digital recording format that is used for audio CDs.

## Playback Control (VCD)

When a VCD has the PBC (Playback Control) function, you can use menu-driven operations and enjoy high-resolution still pictures.

## Sampling Frequency, Quantization Bits

When analog signals are converted into digital signals, they are divided into many points and digitized. This dividing method is called "sampling." The sampling frequency indicates how many points one second is divided into – for example, for CD sound, one second is divided into 44100 points since its sampling frequency is 44.1 kHz. On the other hand, the number of quantization bits indicates the volume size used to memorize each divided point.

The larger this number is, the clearer the sound can be reproduced.

# TROUBLESHOOTING



What appears to be trouble is not always serious. Check the following points before calling a service center.

	Symptoms	Causes	Remedies
General	<ul style="list-style-type: none"> <li>Sound cannot be heard from the speakers.</li> </ul>	The volume level is set to the minimum level.	Adjust it to the optimum level.
		Connections are incorrect.	Check the cords and connections.
	<ul style="list-style-type: none"> <li>This unit does not work at all.</li> </ul>	The built-in microcomputer may have functioned incorrectly due to noise, etc.	Press the reset button on the panel holder after detaching the control panel. (The clock setting and preset stations stored in memory are erased.) (See page 2.)
	<ul style="list-style-type: none"> <li>"Panel Connect Error" appears on the display.</li> </ul>	The control panel is not attach correctly and firmly.	Remove the control panel, wipe the connectors, then attach it again. (See page 58.)
	<ul style="list-style-type: none"> <li>No sound comes out of the 2nd AUDIO OUT plug.</li> </ul>	Dual Zone is not activated	Activate Dual Zone.
FM/AM	<ul style="list-style-type: none"> <li>SSM (Strong-station Sequential Memory) automatic preset does not work.</li> </ul>	Signals are too weak.	Store stations manually.
	<ul style="list-style-type: none"> <li>Static noise while listening to the radio.</li> </ul>	The antenna is not connected firmly.	Connect the antenna firmly.
	<ul style="list-style-type: none"> <li>AM band cannot be selected.</li> </ul>	Dual Zone is activated.	Deactivate Dual Zone.
Disc Playback	<ul style="list-style-type: none"> <li>Disc cannot be played back.</li> </ul>	Disc is inserted upside down.	Insert the disc correctly.
	<ul style="list-style-type: none"> <li>CD-R/CD-RW cannot be played back.</li> <li>Tracks on the CD-R/CD-RW cannot be skipped.</li> </ul>	CD-R/CD-RW is not finalized.	<ul style="list-style-type: none"> <li>Insert a finalized CD-R/CD-RW.</li> <li>Finalize the CD-R/CD-RW with the component which you used for recording.</li> </ul>
	<ul style="list-style-type: none"> <li>Disc cannot be ejected.</li> </ul>	Disc is locked.	Unlock the disc. (See page 41.)
	<ul style="list-style-type: none"> <li>[00'00"] appears on the display, but playback does not start.</li> </ul>	You are playing a Mixed-CD. (Playback stops at the beginning of the first track.)	Skip to the following tracks. Playback start with the selected track. (For details about the Mixed-CD, refer to "A Guide to MP3" (separate volume).
	<ul style="list-style-type: none"> <li>Disc cannot be recognized.</li> </ul>	The CD player may function incorrectly.	While holding SRC, press SEL for more than 2 seconds to eject the disc.



	Symptoms	Causes	Remedies
Disc Playback	<ul style="list-style-type: none"> <li>Sound and picture are sometimes interrupted or distorted.</li> </ul>	You are driving on rough roads.	Stop playback while driving on rough roads.
		Disc is scratched.	Change the disc.
		Connections are incorrect.	Check the cords and connections.
	<ul style="list-style-type: none"> <li>“No Disc” flashes on the display.</li> </ul>	No disc in the loading slot.	Insert a disc into the loading slot.
		Disc is inserted incorrectly.	Insert the disc correctly.
	<ul style="list-style-type: none"> <li>No playback picture (DVD, VCD) appears on the monitor.</li> </ul>	Parking brake wire is not connected.	Connect the wire (see Installation/Connection Manual).
	<ul style="list-style-type: none"> <li>No picture appears on the monitor at all.</li> </ul>	The video cord is not connected correctly.	Connect the video cord correctly
		An incorrect input has been selected on the TV or monitor.	Select a correct input on the TV or monitor.
	<ul style="list-style-type: none"> <li>The left and right edges of the picture are missing on the screen.</li> </ul>	“4:3 PS” is selected when viewing on a conventional TV (aspect ratio 4:3).	Select “4:3 LB.” (See page 45.)
	<ul style="list-style-type: none"> <li>Disc can be neither played back nor ejected.</li> </ul>	The built-in microcomputer may function incorrectly due to noise, etc.	Turn off the power, then turn it on again.
	<ul style="list-style-type: none"> <li>MP3 disc is skipped or cannot be played back.</li> </ul>	MP3 files do not have the extension code—mp3 in their file names.	Add the extension code —mp3 to their file names.
		MP3 files are not recorded in a format compliant with ISO 9660 Level 1, ISO 9660 Level 2, Romeo, or Joliet.	Change the disc. (Record MP3 files using a compliant application.)
	<ul style="list-style-type: none"> <li>Noise is generated while playing an MP3 disc.</li> </ul>	The file played back is not an MP3 file (although it has the extension code—mp3).	Skip to another file or change the disc. (Do not add the extension code—mp3 to non-MP3 files.)
<ul style="list-style-type: none"> <li>MP3 files cannot be played back in the order you have intended them to play.</li> </ul>	Playback order is determined when the files are recorded.	_____	
<ul style="list-style-type: none"> <li>Elapsed playing time is not correct for an MP3 disc.</li> </ul>	This sometimes occurs during play. This is caused by how the files are recorded on the disc.	_____	



Symptoms	Causes	Remedies
<ul style="list-style-type: none"> <li>• “No Disc” flashes on the display.</li> </ul>	No disc is in the magazine.	Insert discs into the magazine.
	Discs are inserted upside down.	Insert discs correctly.
	Discs are unplayable.	Insert playable discs.
	The current disc does not contain any MP3 files.	Insert a disc that contains MP3 files.
<ul style="list-style-type: none"> <li>• “No Magazine” flashes on the display.</li> </ul>	No magazine is loaded in the CD changer.	Insert the magazine.
<ul style="list-style-type: none"> <li>• “Reset 8” flashes on the display.</li> </ul>	This unit is not connected to the CD changer correctly.	Connect this unit and the CD changer correctly and press the reset button on the CD changer.
<ul style="list-style-type: none"> <li>• “Reset 1” – “Reset 7” flashes on the display.</li> </ul>	_____	Press the reset button on the CD changer.
<ul style="list-style-type: none"> <li>• The CD changer does not work at all.</li> </ul>	The built-in microcomputer may function incorrectly due to noise, etc.	Press the reset button on the panel holder after detaching the control panel. (The clock setting and preset stations stored in memory are erased.) (See page 2.)

CD Changer

### Output signals through the DIGITAL OUT terminal

They differ depending on the “DIGITAL AUDIO OUT” setting on the Setup Menu.

DIGITAL AUDIO OUT Playback Disc	Output Signals		
	PCM ONLY	DOLBY DIGITAL/PCM	STREAM/PCM
DVD 48 kHz, 16/20/24 bit Linear PCM	48 kHz, 16 bit Linear PCM *		
96 kHz, Linear PCM	None		
with <b>Dolby Digital</b>	48 kHz, 16 bit Linear PCM	Dolby Digital bitstream	
with <b>DTS</b>	48 kHz, 16 bit Linear PCM		DTS bitstream
with <b>MPEG Multichannel</b>	48 kHz, 16 bit Linear PCM		MPEG bitstream
<b>Video CD, Audio CD</b>	44.1 kHz, 16 bit Linear PCM		
<b>Audio CD with DTS</b>	44.1 kHz, 16 bit Linear PCM		DTS bitstream
<b>MP3</b>	Linear PCM		

\* While playing some DVDs, digital signals may be emitted at 20 bits or 24 bits (at their original bit rate) through the DIGITAL OUT terminal if the discs are not copy-protected.



# MAINTENANCE

## Handling discs

This unit has been designed to reproduce DVD-Videos, VCDs, CDs, CD-Rs (Recordable), CD-RWs (Rewritable), and CD Texts.

- This unit is also compatible with MP3 discs.

### How to handle discs

**When removing a disc from its case**, press down the center holder of the case and lift the disc out, holding it by the edges.

Center holder



- Always hold the disc by the edges. Do not touch its recording surface.

**When storing a disc into its case**, gently insert the disc around the center holder (with the printed surface facing up).

- Make sure to store discs into the cases after use.

### To keep discs clean

A dirty disc may not play correctly. If a disc does become dirty, wipe it with a soft cloth in a straight line from center to edge.



### To play new discs

New discs may have some rough spots around the inner and outer edges. If such a disc is used, this unit may reject the disc.

To remove these rough spots, rub the edges with a pencil or ball-point pen, etc.



### Moisture condensation

Moisture may condense on the lens inside the CD player in the following cases:

- After starting the heater in the car.
- If it becomes very humid inside the car.

Should this occur, the CD player may malfunction. In this case, eject the disc and leave the unit turned on for a few hours until the moisture evaporates.

## When playing a CD-R or CD-RW

Before playing back CD-Rs or CD-RWs, read their instructions or cautions carefully.

- Use only “finalized” CD-Rs or CD-RWs.
- Some CD-Rs or CD-RWs may not play back on this unit because of their disc characteristics, and for the following reasons:
  - Discs are dirty or scratched.
  - Moisture condensation on the lens inside the unit.
  - The pickup lens inside the unit is dirty.
- CD-RWs may require a longer readout time since the reflectance of CD-RWs is lower than that of regular CDs.
- CD-Rs or CD-RWs are susceptible to high temperatures or high humidity, so do not leave them inside your car.
- Do not use the following CD-Rs or CD-RWs:
  - Discs with stickers, labels, or a protective seal stuck to the surface.
  - Discs on which labels can be directly printed by an ink jet printer.

Using these discs under high temperatures or high humidity may cause malfunctions or damage to discs. For example,

- Stickers or labels may shrink and warp a disc.
- Stickers or labels may peel off so discs cannot be ejected.
- Print on discs may get sticky.

Read instructions or cautions about labels and printable discs carefully.

#### CAUTIONS:

- Do not insert any disc of unusual shape—like a heart or flower; otherwise, it will cause a malfunction.
- Do not expose discs to direct sunlight or any heat source or place them in a place subject to high temperature and humidity. Do not leave them in a car.
- Do not use any solvent (for example, conventional record cleaner, spray, thinner, benzene, etc.) to clean discs.

Warped disc



Sticker



Sticker residue

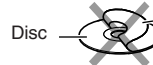

Stick-on label



## AUDIO AMPLIFIER SECTION

Maximum Power Output:

Front: 50 W per channel

Rear: 50 W per channel

Continuous Power Output (RMS):

Front: 19 W per channel into 4  $\Omega$ , 40 Hz to 20 000 Hz at no more than 0.8% total harmonic distortion.

Rear: 19 W per channel into 4  $\Omega$ , 40 Hz to 20 000 Hz at no more than 0.8% total harmonic distortion.

Load Impedance: 4  $\Omega$  (4  $\Omega$  to 8  $\Omega$  allowance)

Equalizer Control Range:

Frequencies: 60 Hz, 150 Hz, 400 Hz, 1 kHz, 2.4 kHz, 6 kHz, 12 kHz

Level:  $\pm 10$  dB

Signal-to-Noise Ratio: 70 dB

Audio output level:

Analog (2nd AUDIO OUT): 6 mW (at 16  $\Omega$ )

Digital (DIGITAL OUT: Optical):

Signal wave length: 660 nm

Output level:  $-21$  dBm to  $-15$  dBm

Line-Out Level/Impedance:

2.0 V/20 k $\Omega$  load (full scale)

Output Impedance: 1 k $\Omega$

Color system: PAL/NTSC

Video output (composite): 1 V<sub>p-p</sub>/75  $\Omega$

## TUNER SECTION

Frequency Range:

FM: 87.5 MHz to 108.0 MHz

AM: 531 kHz to 1 602 kHz

### [FM Tuner]

Usable Sensitivity: 11.3 dBf (1.0  $\mu$ V/75  $\Omega$ )

50 dB Quieting Sensitivity: 16.3 dBf (1.8  $\mu$ V/75  $\Omega$ )

Alternate Channel Selectivity (400 kHz): 65 dB

Frequency Response: 40 Hz to 15 000 Hz

Stereo Separation: 35 dB

Capture Ratio: 1.5 dB

### [AM Tuner]

Sensitivity: 20  $\mu$ V

Selectivity: 35 dB

## DVD/CD PLAYER SECTION

Signal Detection System: Non-contact optical pickup (semiconductor laser)

Number of channels: 2 channels (stereo)

Frequency Response:

DVD, fs=48 kHz: 16 Hz to 22 000 Hz

DVD, fs=96 kHz: 16 Hz to 44 000 Hz

VCD, CD, MP3: 16 Hz to 20 000 Hz

Dynamic Range: 96 dB

Signal-to-Noise Ratio: 98 dB

Wow and Flutter: Less than measurable limit

MP3 recording format: MPEG 1/2 Audio Layer 3

Max. Bit rate: 320 Kbps

## GENERAL

Power Requirement:

Operating Voltage:

DC 14.4 V (11 V to 16 V allowance)

Grounding System: Negative ground

Allowable Operating Temperature:

0°C to +40°C

Dimensions (W  $\times$  H  $\times$  D):

Installation Size (approx.):

182 mm  $\times$  52 mm  $\times$  158 mm

Panel Size (approx.):

188 mm  $\times$  58 mm  $\times$  12 mm

Mass (approx.):

1.7 kg (excluding accessories)

*Design and specifications are subject to change without notice.*

### **About mistracking:**

*Mistracking may result from driving on extremely rough roads. This does not damage the unit and the disc, but will be annoying.*

*We recommend that you stop disc play while driving on such rough roads.*

**Having TROUBLE with operation?  
Please reset your unit**

Refer to page of How to reset your unit

**在操作時遇到麻煩了?  
請重設本機**

參閱如何重設本機之頁數。

**작동에 문제가 있으십니까?  
장치 재설정에 관한 설명을 참조하여  
장치를 재설정하십시오.**

**หากมีปัญหาในการทำงาน  
กรุณากดปุ่มตั้งค่าเริ่มต้นใหม่  
กรุณาดูหน้าวิธีตั้งค่าเครื่องใหม่**

**JVC**

VICTOR COMPANY OF JAPAN, LIMITED



EN, CH, KO, TH

© 2003 VICTOR COMPANY OF JAPAN, LIMITED



0503MNMMDWJEIN



# KD-DV5000

## Installation/Connection Manual

安裝/連接手冊

설치/연결 설명서

การติดตั้ง/คู่มือการติดตั้ง

LVT1055-003A  
[U]

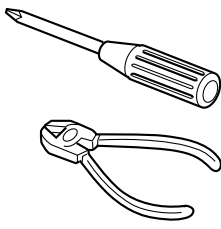

0503MNMMDWJEIN  
EN, CH, KO, TH

### ENGLISH

- This unit is designed to operate on 12 V DC, NEGATIVE ground electrical systems.

## WARNINGS

- DO NOT install any unit in locations where;
  - it may obstruct the steering wheel and gearshift lever operations, as this may result in a traffic accident.
  - it may obstruct the operation of safety devices such as air bags, as this may result in a fatal accident.
  - it may obstruct visibility.
- DO NOT operate any unit while manipulating the steering wheel, as this may result in a traffic accident.
- The driver must not watch the monitor while driving.
  - If the driver watches the monitor while driving, it may lead to carelessness and cause an accident.
- The driver must not put on the headphones while driving. It is dangerous to shut off the outside sounds while driving.
- If you need to operate the unit while driving, be sure to look ahead carefully or you may be involved in a traffic accident.
- If the parking brake is not engaged, "DRIVER MUST NOT WATCH THE MONITOR WHILE DRIVING." appears on the monitor, and no playback picture will be shown.
  - This warning appears only when the parking brake wire is connected to the parking brake system built in the car.

### 中文

- 此機組被設計以 12 V DC 負地電氣系統操作。

## 警告

- 切勿將機器安裝在下述位置；
  - 妨礙駕駛和操縱桿操作的位置，因為安裝在該位置可能引發交通事故。
  - 妨礙如氣袋等安全裝置操作的位置，因為安裝在該位置可能引發交通事故。
  - 妨礙視野的位置。
- 切勿在駕駛汽車的過程中操作任何機器，因為此舉可能引發交通事故。
- 在駕駛過程中司機不可以觀看監視器。
  - 若司機在駕駛過程中觀看監視器，可能因為注意力不集中而導致意外事故的發生。
- 在駕駛過程中司機不可以戴頭戴耳機。
- 在駕駛過程中隔絕外界聲音非常危險。
- 在駕駛過程中若需要操作機器，切記要密切注意前方，否則可能招致車禍。
- 若手剎車未啮合，"DRIVER MUST NOT WATCH THE MONITOR WHILE DRIVING." (在駕駛過程中司機不可以觀看監視器。)字樣會在監視器上出現，並且無法播出圖像。
  - 僅當手剎車導線與汽車內置的手剎車系統相連接時此警告信息才會出現（參閱安裝/連接手冊）。

### 한국어

- 이 장치는 12 V DC, 네거티브 접지 전기 시스템에서만 사용하도록 설계되어 있습니다.

## 경고

- 다음과 같은 곳에는 장치를 설치하지 마십시오.
  - 자동차 핸들과 기어샤프트 레버의 원활한 작동을 방해하여 교통 사고를 유발할 가능성이 있는 곳.
  - 에어백과 같은 안전 장치의 작동을 방해하여 치명적인 교통 사고를 유발할 가능성이 있는 곳.
  - 운전자의 시야를 가릴 수 있는 곳.
  - 교통 사고의 위험이 있으니 핸들 조작 중에 장치를 작동하지 마십시오.
  - 운전 중에 모니터를 보지 마십시오. 운전 중에 모니터를 보면 주의가 산만해져 사고 위험이 있습니다.
  - 운전 중에는 헤드폰을 사용하지 마십시오. 운전 중에 외부의 소리를 차단하는 것은 위험합니다.
  - 운전 중에 장치를 작동해야 하는 경우 전방을 잘 살피십시오. 그렇지 않으면 교통 사고가 발생할 수 있습니다.
  - 주차 브레이크가 걸리지 않으면 모니터에 "DRIVER MUST NOT WATCH THE MONITOR WHILE DRIVING." 표시되고 재생 화상이 나타나지 않습니다.
  - 이러한 경고는 자동차에 내장된 제동 시스템에 주차 브레이크 배선이 연결되어 있을 때만 나타납니다(설치/연결 설명서 참조).

### ไทย

- เครื่องนี้ได้รับการออกแบบสำหรับใช้งานกับระบบไฟกระแสตรงที่ต่อสายดินเป็นขั้วลบขนาด 12 โวลท์

## คำเตือน

- อย่าติดตั้งเครื่องในที่ใดก็ตามที่
  - อาจกีดขวางการทำงานของพวงมาลัยและคันเกียร์ เพราะอาจก่อให้เกิดอุบัติเหตุ
  - อาจกีดขวางการทำงานของอุปกรณ์ป้องกันความปลอดภัย เช่น แอร์แบค เพราะอาจก่อให้เกิดอันตรายร้ายแรงถึงชีวิตขึ้นได้
  - อาจกีดขวางสายตา
- อย่าใช้งานขณะขับขี่ เพราะอาจก่อให้เกิดอุบัติเหตุขึ้นได้
- ผู้ขับขี่ต้องไม่มองที่จอขณะที่ขับขี่ ถ้าผู้ขับขี่มองที่จอขณะที่ขับขี่ อาจนำไปสู่ความประมาท และเป็นสาเหตุให้เกิดอุบัติเหตุขึ้นได้
- ผู้ขับขี่ต้องไม่ใส่หูฟังขณะขับขี่ เพราะการปิดหูไม่รับฟังเสียงจากภายนอกอาจก่อให้เกิดอันตรายขึ้นได้
- ถ้าจำเป็นต้องใส่หูฟังขณะขับขี่ ขอให้หาทางข้างหน้าที่มีเสียงนั้นอาจเกิดอุบัติเหตุขึ้นได้
- ถ้าไม่ได้ขึ้นเบรกมือไว้ จอมอนิเตอร์จะแสดงข้อความ "ผู้ขับขี่ต้องไม่ดูที่จอขณะที่ขับขี่" "DRIVER MUST NOT WATCH THE MONITOR WHILE DRIVING." จะปรากฏขึ้นบนหน้าจอ และเครื่องจะไม่เล่น
- คำเตือนนี้จะปรากฏขึ้นเฉพาะเมื่อต่อสายเบรกกับระบบเบรกในรถยนต์ไว้เท่านั้น (ดูคู่มือการติดตั้ง/ต่อสาย)

## Parts list for installation and connection

The following parts are provided with this unit. After checking them, please set them correctly.

### Hard case/Control panel

硬盒 / 控制面板  
하드 케이스/제어판  
ถังบรรจุ/หน้าปัด

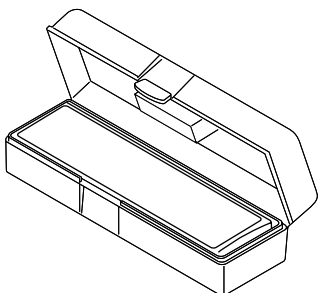

### Sleeve

外套機殼  
슬리브  
ปลอกหุ้ม

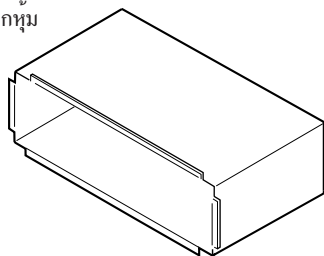

### Trim plate

裝飾框  
트림 플레이트  
แผ่นโลหะขอบแดง

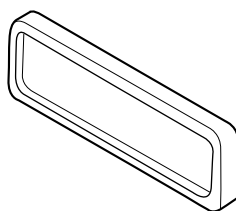

### Power cord

電路連接用的配線束  
전원 코드  
สายเคเบิลกำลัง

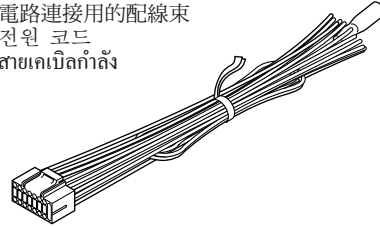

### Remote controller

遙控器  
리모트 컨트롤  
รีโมทคอนโทรล

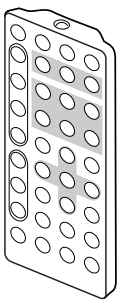

### Battery

電池  
배터리  
แบตเตอรี่



CR2025

### Washer (ø5)

墊圈 (ø5)  
와셔 (ø5)  
ประเก็นวงแหวน (ø5)



### Lock nut (M5)

鎖定螺母 (M5)  
잠금장치 너트 (M5)  
นอตล็อก (M5)



### Mounting bolt (M5 x 20 mm)

緊固螺栓 (M5 x 20 mm)  
장착 볼트 (M5 x 20 mm)  
สลักติด (M5 x 20 มิลลิเมตร)



### Rubber cushion

橡膠防震墊  
고무 쿠션  
ยางกันกระแทก



### Handles

板條型把手  
손잡이  
คันบังคับ

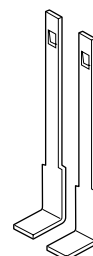

### Crimp connector

夾子接頭  
크림프 커넥터  
หัวต่อสำหรับหนีบ

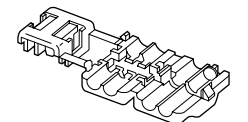

## TROUBLESHOOTING

- The fuse blows.**
  - \* Are the red and black leads connected correctly?
- Power cannot be turned on.**
  - \* Is the yellow lead connected?
- No sound from the speakers.**
  - \* Is the speaker output lead short-circuited?
- Sound is distorted.**
  - \* Is the speaker output lead grounded?
  - \* Are the "–" terminals of L and R speakers grounded in common?
- Unit becomes hot.**
  - \* Is the speaker output lead grounded?
  - \* Are the "–" terminals of L and R speakers grounded in common?

## 故障排除

- 保險絲燒斷。**
  - \* 檢查紅色導線接頭和黑色導線接頭是否連接正確？
- 電源不能接通。**
  - \* 檢查黃色導線接頭是否接上？
- 揚聲器沒有聲音。**
  - \* 檢查揚聲器輸出導線接頭是否短路？
- 聲音失真。**
  - \* 檢查揚聲器輸出端子是否接地？
  - \* 檢查揚聲器的左 (L)、右 (R) 端子的負極 (–) 是否共同接地？
- 本機發熱。**
  - \* 檢查揚聲器輸出端子是否接地？
  - \* 檢查揚聲器的左 (L)、右 (R) 端子的負極 (–) 是否共同接地？

## 문제 해결

- 퓨즈가 끊어집니다.**
  - \* 빨간색 및 검정색 도선이 올바르게 연결되어 있습니까?
- 전원이 들어오지 않습니다.**
  - \* 노란색 도선이 연결되어 있습니까?
- 스피커에서 소리가 나지 않습니다.**
  - \* 스피커 출력 도선이 단락되지 않았습니까?
- 소리가 정확한 음을 내지 못합니다.**
  - \* 스피커 출력 도선이 접지되어 있습니까?
  - \* 왼쪽/오른쪽 스피커의 "–" 단자가 같이 접지되어 있습니까?
- 장치가 과열됩니다.**
  - \* 스피커 출력 도선이 접지되어 있습니까?
  - \* 왼쪽/오른쪽 스피커의 "–" 단자가 같이 접지되어 있습니까?

## การตรวจสอบปัญหาขัดข้อง

- ฟิวส์ขาด**
  - \* มีการเชื่อมสายตะกั่วสีและสีแดงอย่างถูกต้องหรือไม่
- ไม่สามารถเปิดเครื่องได้**
  - \* มีการเชื่อมสายตะกั่วสีเหลืองหรือไม่
- ไม่มีเสียงออกจากลำโพง**
  - \* สายตะกั่วส่วนที่ออกทางลำโพงเกิดไฟฟ้ลัดวงจรหรือไม่
- เสียงเพี้ยน**
  - \* สายตะกั่วส่วนที่ออกทางลำโพงต่อลงดินหรือไม่
  - \* สายขั้วลบ ของลำโพงด้านซ้ายและขวาต่อลงดินตามปกติหรือไม่
- ชุดประเก็นร้อนขึ้น**
  - \* สายตะกั่วที่ออกทางลำโพงต่อลงดินหรือไม่
  - \* สายขั้วลบ ของลำโพงด้านซ้ายและขวาต่อลงดินตามปกติหรือไม่

# INSTALLATION (IN-DASH MOUNTING)

# 安裝 (裝設、固定在儀 表板內)

# 설치 (계기판 장착 형)

# การติดตั้ง (การประกอบแผงหน้าปัด)

The following illustration shows a typical installation. However, you should make adjustments corresponding to your specific car. If you have any questions or require information regarding installation kits, consult your JVC car audio dealer or a company supplying kits.

下面的圖解表示了典型的安裝程序。然而，您應當做些適當的調整，以便適應您自己的汽車。如果您有問題，或需要有關配套元件的資料，請向 JVC 汽車音響分銷商或配套元件供應公司詢問。

다음 그림은 가장 일반적인 설치 방법을 보여줍니다. 그러나 자동차에 따라 몇 가지 조정이 필요합니다. 설치 키트에 대해 질문이 있거나 정보가 필요하다면 JVC 자동차 판매점이나 키트 공급업체에 문의하십시오.

ภาพตัวอย่างต่อไปนี้แสดงถึงการติดตั้งแบบทั่วไป อย่างไรก็ตาม ควรปรับแต่งให้เหมาะสมกับรถของคุณเอง หากคุณมีปัญหาก็ขอการข้อมูลเพิ่มเติมเกี่ยวกับชุดติดตั้ง กรุณาปรึกษากับผู้ขายเครื่องเสียงรถยนต์ JVC ของท่านหรือบริษัทที่จำหน่ายชุดติดตั้งนี้

**1 Before mounting:** Press  (control panel release button) to detach the control panel if already attached.

\* When shipped from the factory, the control panel is packed in the hard case.

**2** Remove the trim plate.

**3** Remove the sleeve after disengaging the sleeve locks.

① Stand the unit.

**Note:** When you stand the unit, be careful not to damage the fuse on the rear.

② Insert the 2 handles between the unit and the sleeve, as illustrated, to disengage the sleeve locks.

③ Remove the sleeve.

**Note:** Be sure to keep the handles for future use after installing the unit.

**4** Install the sleeve into the dashboard.

\* After the sleeve is correctly installed into the dashboard, bend the appropriate tabs to hold the sleeve firmly in place, as illustrated.

**5** Fix the mounting bolt to the rear of the unit's body and place the rubber cushion over the end of the bolt.

**6** Do the required electrical connections.

**7** Slide the unit into the sleeve until it is locked.

**8** Attach the trim plate.

**9** Attach the control panel.

**1** 裝設之前：如果控制面板已經裝上，按下  (控制面板解脫按鈕)，拆脫控制面板。

\* 當控制面板從工廠裝運時，它是包裝在硬盒中的。

**2** 取下裝飾框。

**3** 解開扣板，取下本機的外套機殼。

① 將本機豎起。

**注意：**您豎起本機時，小心不要損壞底部的保險絲。

② 按圖所示，在本機和外套機殼之間插入兩片板條型的把手，解開外套機殼扣板。

③ 取下外套機殼。

**注意：**安裝本機後，務必保存好兩片把手，以備將來使用。

**4** 將外套機殼裝入儀表板內。

\* 在外套機殼準確地裝入儀表板之後，按圖所示，彎曲機殼的突舌，把外套機殼牢固在儀表板內。

**5** 將緊固螺栓旋緊在本機機體上，並將橡膠防震墊套在緊固螺栓的尾部。

**6** 進行所需的電路連接。

**7** 將本機滑入外套機殼，直到扣板鎖住為止。

**8** 裝上裝飾框。

**9** 裝上控制面板。

**1** 장착하기 전에: 제어판을 이미 부착하였으면  (제어판 해제 단추)를 눌러 제어판을 분리합니다.

\* 제어판은 공장에서 하드 케이스에 포장된 상태로 출고됩니다.

**2** 트림 플레이트를 분리합니다.

**3** 슬리브 잠금장치를 풀 후 슬리브를 분리합니다.

① 장치를 세웁니다.

**참고:** 장치를 세울 때 뒤쪽의 퓨즈가 손상되지 않도록 주의하십시오.

② 그림과 같이 장치와 슬리브 사이에 두 개의 손잡이를 끼워 슬리브 잠금장치를 풀습니다.

③ 슬리브를 분리합니다.

**참고:** 장치를 설치한 후 나중에 사용할 수 있도록 손잡이를 잘 보관합니다.

**4** 슬리브를 대시보드에 설치합니다.

\* 슬리브를 대시보드에 올바르게 설치한 후 그림과 같이 해당 탭을 구부려 제자리에 단단히 고정시킵니다.

**5** 장치 본체 뒤쪽에 장착 볼트를 고정시키고 볼트 끝에 고무 쿠션을 끼웁니다.

**6** 전기 연결을 합니다.

**7** 슬리브가 제자리에 끼워질 때까지 장치를 밀어 넣습니다.

**8** 트림 플레이트를 끼웁니다.

**9** 제어판을 장착합니다.

**1** ก่อนประกอบ กดปุ่ม  (ใช้ถอดแผงควบคุมออก) เพื่อออกจากแผงควบคุม

\* เมื่อผลิตภัณฑ์ถูกส่งออกจากโรงงานแผงหน้าปัดจะบรรจุไว้ในลังแข็ง

**2** ถอดแผ่นโลหะขอบแผงออก

**3** ถอดปลอกหุ้มออกหลังจากปลดที่ล็อกปลอกหุ้มออกแล้ว

① จับชุดประกอบตั้งขึ้น

**หมายเหตุ:** เมื่อคุณตั้งชุดประกอบขึ้น ระวังอย่าทำให้หัวสักริวส่วนท้ายเสียหาย

② ใส่คั่นบังคับ 2 อันระหว่างชุดประกอบกับปลอกหุ้ม (ดังภาพ) เพื่อปลดที่ล็อกปลอกหุ้มออกจากกัน

③ ปลดปลอกหุ้มออก

**หมายเหตุ:** ระวังอย่าให้คั่นบังคับสามารถใช้งานได้อีกต่อไปหลังจากติดตั้งชุดประกอบแล้ว

**4** ติดตั้งปลอกหุ้มลงในแผงหน้าปัด

\* หลังจากติดตั้งปลอกหุ้มลงในแผงหน้าปัดอย่างถูกต้องแล้วติดตั้งโหม่งพืดที่ปลอกหุ้มจะถูกยึดไว้อย่างแน่นหนา (ดังภาพ)

**5** ติดสติกประกอบบริเวณด้านหลังโครงของชุดประกอบและวางขั้วกันกระแทกไว้บนส่วนปลายของสติก

**6** ต่อสายไฟตามที่กำหนดไว้ทั้งหมด

**7** เสียบชุดประกอบลงในปลอกหุ้มจนเข้ากันได้พอดี

**8** ต่อแผ่นโลหะขอบแผง

**9** ต่อเข้ากับแผงควบคุม

**1**

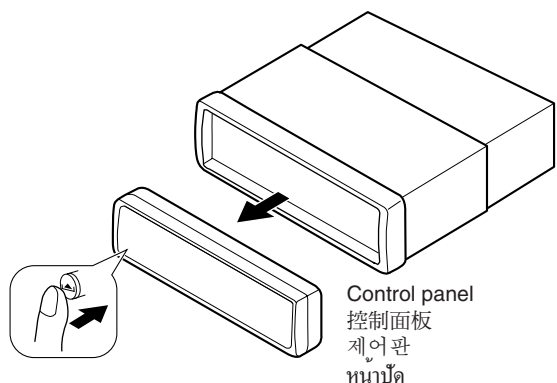

Control panel  
控制面板  
제어판  
หน้าปัด

**2**

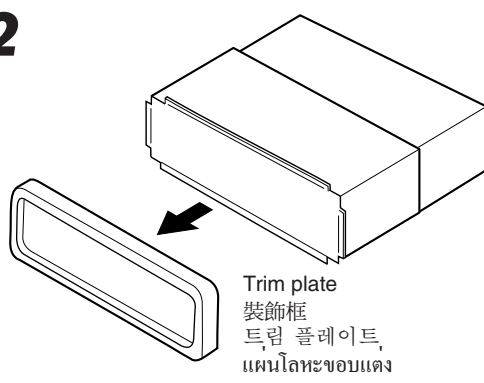

Trim plate  
裝飾框  
트림 플레이트,  
แผ่นโลหะขอบแผง

**3**

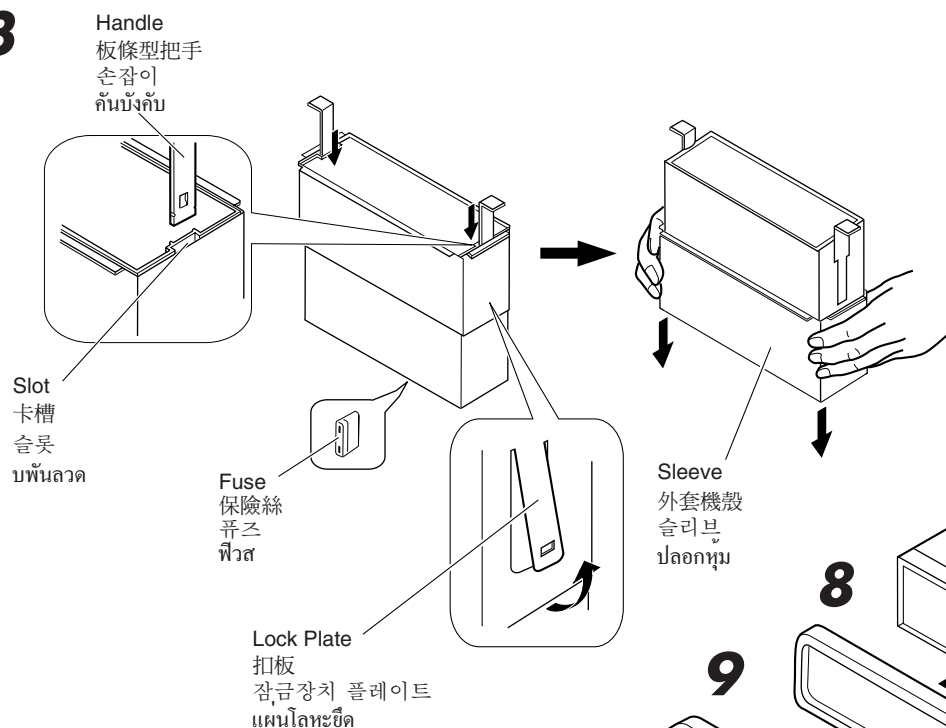

Handle  
板條型把手  
손잡이  
คั่นบังคับ

Slot  
卡槽  
슬롯  
บัพันลวด

Fuse  
保險絲  
퓨즈  
ฟิวส์

Lock Plate  
扣板  
잠금장치 플레이트  
แผ่นโลหะขีด

Sleeve  
外套機殼  
슬리브  
ปลอกหุ้ม

Control panel  
控制面板  
제어판  
หน้าปัด

Trim plate  
裝飾框  
트림 플레이트,  
แผ่นโลหะขอบแผง

Rubber cushion  
橡膠防震墊  
고무 쿠션  
ยางกันกระแทก

Dashboard  
儀表板  
대시보드  
แผงหน้าปัด

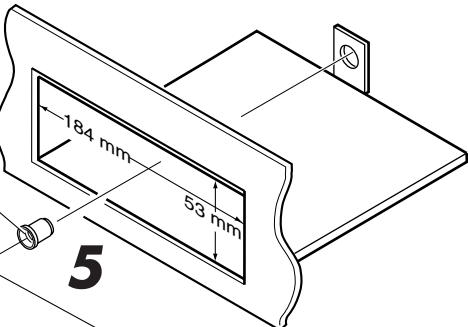

Mounting bolt  
緊固螺栓  
장착 볼트  
สลักติด

**4\***

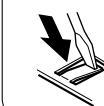

**6**

See "ELECTRICAL CONNECTIONS."  
請參閱“電路連接”。  
“전기 연결” 참조.  
กรุณาดูหัวข้อ “การเชื่อมโดยใช้ไฟฟ้า”

- When using the optional stay
- 若選用支撐架
- 선택 품목인 지지대를 사용하는 경우
- เมื่อใช้ตัวยึดแบบเลือกได้

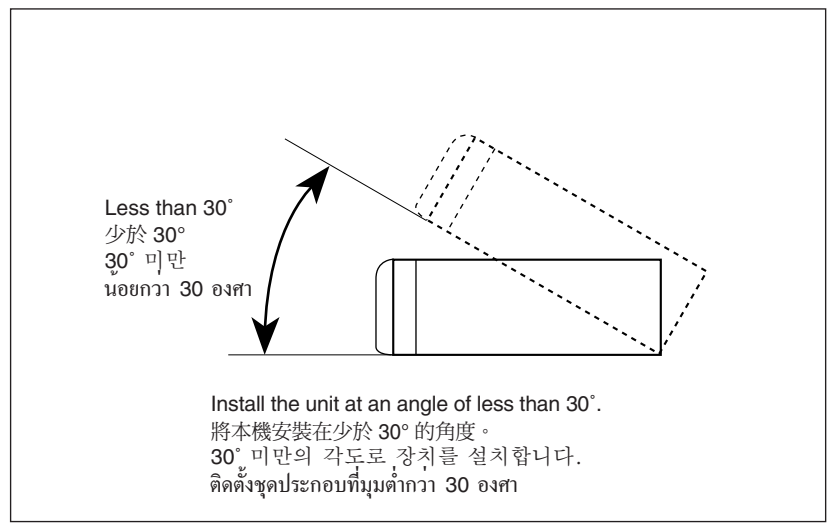
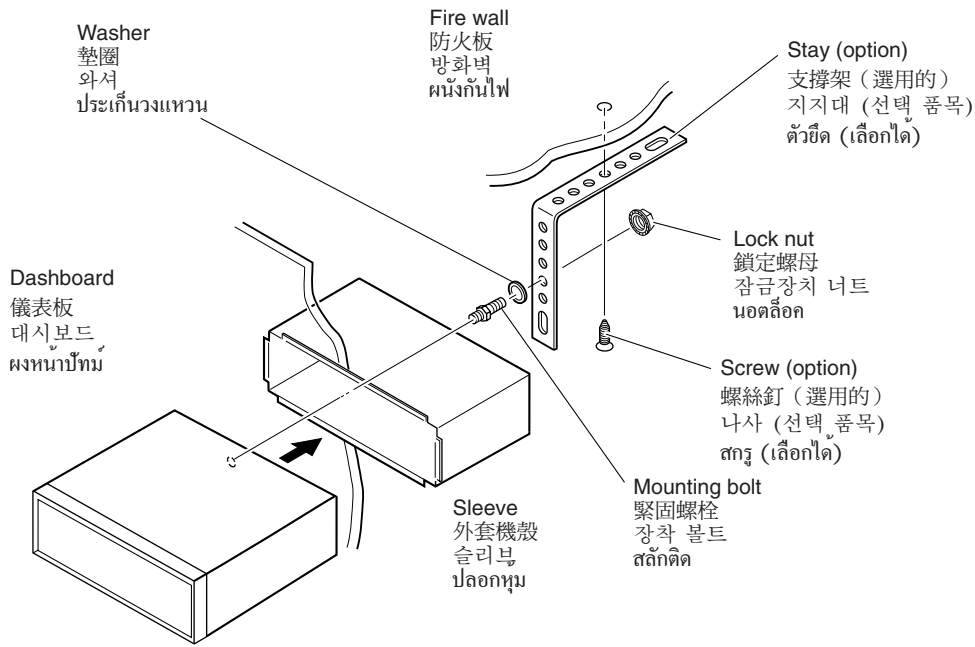

• When installing the unit without using the sleeve

In a Toyota for example, first remove the car radio and install the unit in its place.

- 若不使用外套機殼安裝本機
- 以豐田牌 (TOYOTA) 汽車為例：首先取出汽車收音機，然後將本機裝入其空出的位置。

• 슬리브를 사용하지 않고 장치를 설치하는 경우

한 예로 도요타에서는 자동차 라디오를 떼어내고 그 자리에 이 장치를 설치합니다.

• เมื่อติดตั้งชุดประกอบโดยไม่ใช้ปลอกหุ้ม

ตัวอย่างเช่น ในรถยนต์โตโยต้าให้ถอดวิทยุติดรถยนต์ออกก่อนและติดตั้งชุดประกอบนี้เข้าไปแทน

Flat type screws—M5 x 8 mm \*  
平頭螺絲釘 (M5 x 8 mm) \*  
일자 나사 (M5 x 8 mm) \*  
สกรูหัวเรียบ (M5 x 8 มิลลิเมตร) \*

Bracket\*  
托座\*  
브래킷\*  
แท่นรองรับ\*

Pocket  
空殼  
กระเป๋า

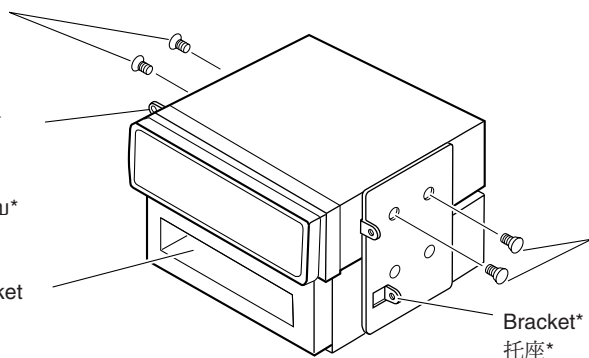

Flat type screws—M5 x 8 mm \*  
平頭螺絲釘 (M5 x 8 mm) \*  
일자 나사 (M5 x 8 mm) \*  
สกรูหัวเรียบ (M5 x 8 มิลลิเมตร) \*

Bracket\*  
托座\*  
브래킷\*  
แท่นรองรับ\*

**Note** : When installing the unit on the mounting bracket, make sure to use the 8 mm long screws. If longer screws are used, they could damage the unit.

**注意** : 把本機安裝在托座上時，務必使用 8 mm 長的螺絲釘。如使用過長的螺絲釘，會損壞本機。

**참고** : 장착 브래킷에 장치를 설치할 때는 반드시 8 mm 길이의 나사를 사용하십시오. 길이가 8 mm가 넘는 나사를 사용하면 장치가 손상될 수 있습니다.

**หมายเหตุ** : เมื่อติดตั้งชุดประกอบลงในแท่นรองรับไว้ให้ใช้สกรูยาวขนาด 8 มิลลิเมตร ถ้าใช้สกรูยาวกว่านี้อาจทำให้ชุดประกอบเสียหายได้

Removing the unit

- Before removing the unit, release the rear section.
- 1 Remove the control panel.
- 2 Remove the trim plate.
- 3 Insert the 2 handles into the slots, as shown. Then, while gently pulling the handles away from each other, slide out the unit. (Be sure to keep the handles after installing it.)

拆卸本機

- 在拆卸本機前，應將本機後部的固定和連接部分鬆開。
- 1 拆下控制面板。
- 2 取下裝飾框。
- 3 按圖所示，將兩片板條型把手插入卡槽，然後輕穩地從兩側向外拉兩片把手，本機隨之拉出。（安裝本機後，務必保存好兩片把手。）

장치 분리

- 장치를 분리하기 전에 뒷부분을 떼어냅니다.
- 1 제어판을 분리합니다.
- 2 트림 플레이트를 떼어냅니다.
- 3 그림과 같이 두 개의 손잡이를 슬롯에 끼웁니다. 그런 다음 서로 간격이 벌어지도록 두 손잡이를 당기면서 장치를 밖으로 밀어냅니다. (설치 후 손잡이를 잘 보관하십시오.)

การถอดชุดประกอบ

- ก่อนจะถอดชุดประกอบ ให้ปลดหน้าตัดส่วนท้ายก่อน
- 1 ถอดแผงควบคุม
- 2 ถอดแผ่นโลหะขอบแต่ง
- 3 ใส่ลิ้นบังคับ 2 อันลงในร่องสำหรับไข้พื้นลวด ดังภาพ จากนั้นให้เลื่อนชุดประกอบออกในขณะที่ค่อย ๆ ดึงลิ้นบังคับทั้งสองอันออกจากกัน (ดูให้ลิ้นบังคับทั้งสองอันอยู่ในตำแหน่งที่เหมาะสมหลังจากติดตั้งแล้ว)

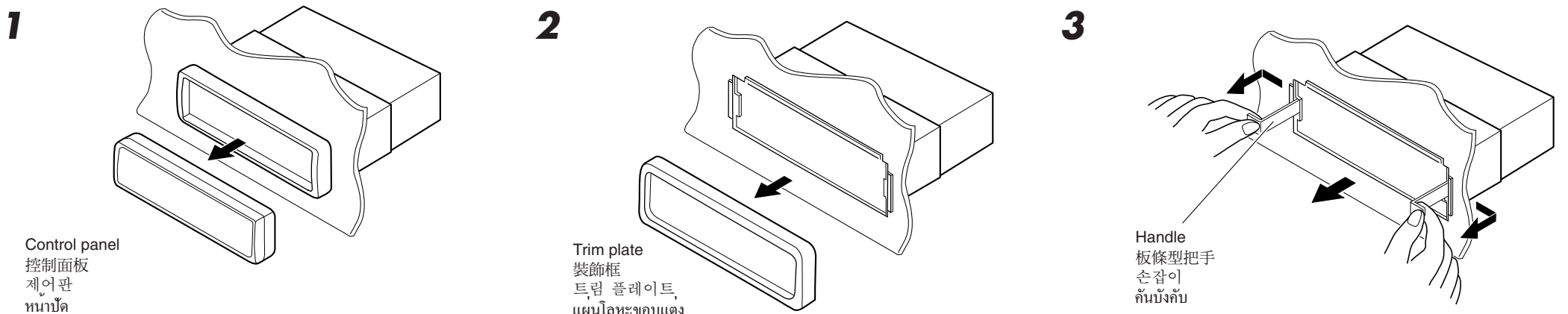

Connecting the leads / 導線接頭的連接 / 도선 연결 / ต่อสายตะกั่ว

Twist the core wires when connecting.  
連接時扭轉線芯。  
연결할 때 코어 전선을 꼬으십시오.  
บิดเส้นลวดแกนเพื่อเชื่อมต่อ

Solder the core wires to connect them securely.  
將線芯牢固地焊接在一起。  
코어 전선들이 안전하게 연결되도록 납땜합니다.  
เชื่อมบัดกรีเส้นลวดแกนทั้งหมดเข้าด้วยกัน เพื่อความปลอดภัยในการทำงาน

CAUTION / 注意 / 주의 / ข้อควรระวัง

- To prevent short-circuit, cover the terminals of the UNUSED leads with insulating tape.
- 為防止電源短路，請用絕緣帶包住未使用電線的端子。
- 전선이 단락되지 않도록 사용하지 않는 도선의 단자에 절연 테이프를 붙이십시오.
- การป้องกันการลัดวงจร จะต้องพันขั้วสายตะกั่วที่ไม่ใช้แล้วด้วยเทปพันสายไฟ

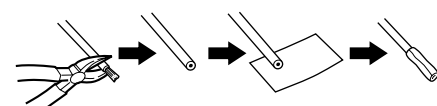

# ELECTRICAL CONNECTIONS

To prevent short circuits, we recommend that you disconnect the battery's negative terminal and make all electrical connections before installing the unit. If you are not sure how to install this unit correctly, have it installed by a qualified technician.

**Note:**  
This unit is designed to operate only on **12 V DC, NEGATIVE ground electrical systems**. If your vehicle does not have this system, a voltage inverter is required, which can be purchased at JVC car audio dealers.

- Replace the fuse with one of the specified rating. If the fuse blows frequently, consult your JVC car audio dealer.
- If noise is a problem...  
This unit incorporates a noise filter in the power circuit. However, with some vehicles, clicking or other unwanted noise may occur. If this happens, connect the unit's **rear ground terminal** (see connection diagram) to the car's chassis using shorter and thicker cords, such as copper braiding or gauge wire. If noise still persists, consult your JVC car audio dealer.
- Maximum input of the speakers should be more than 50 W at the rear and 50 W at the front, with an impedance of **4 Ω to 8 Ω**.
- **Be sure to ground this unit to the car's chassis.**
- The heat sink becomes very hot after use. Be careful not to touch it when removing this unit.

# 電路連接

為防止短路，建議在安裝本機之前，斷開電池的負極，並把所有電路都連接好。如果您不能確定如何正確地安裝本機，應請合格的技術人員來安裝。

- 注意：
- 本機僅可使用直流 **12V**、負極接地的電源系統。如果您的車輛沒有這一電源系統，則需要一個電壓變換器，可以在 JVC 汽車音響分銷商處買到。
- 把保險絲更換為額定負荷值的保險絲。如果保險絲經常燒壞，請向 JVC 汽車音響分銷商詢問。
  - 若出現噪音問題...  
本機在電源回路帶有一個噪音濾波器。但是，在某些車輛上，會出現咯咯聲或其它噪音。如果發生這類情況，將本機後面的接地端子用短而粗的導線，如編織銅線或標準電纜，連接到汽車底盤上（參閱電路接線圖）。如果噪音仍然持續存在，請向 JVC 汽車音響分銷商詢問。
  - 後置和前置揚聲器的最大輸入功率應大於 **50 W** 其阻抗為 **4 Ω - 8 Ω**。
  - 務必將本機的地線接到汽車底盤上。
  - 本機使用後，散熱片會很熱。因此，在移出本機時，小心不要觸摸散熱片。

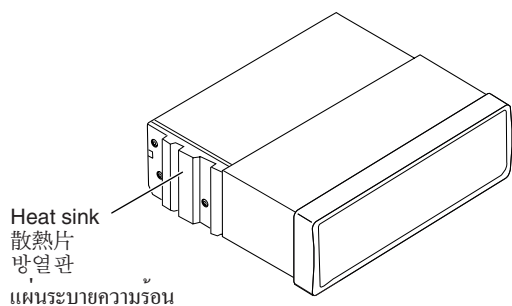

# 전기 연결

전선의 단락을 방지하기 위해, 장치를 설치하기 전에 배터리의 음극 단자를 분리한 후 모든 전기 연결을 수행하십시오. 정확한 장치 설치 방법을 잘 모르면 공인 기술자에게 설치를 의뢰하십시오.

- 참고:**  
이 장치는 **12 V DC, 네거티브 접지 전기 시스템**에서만 사용하도록 설계되었습니다. 차량에 이 전기 시스템이 없으면 변압기가 필요합니다. 이러한 변압기는 JVC 자동차 오디오 판매점에서 구입할 수 있습니다.
- 퓨즈 교체 시 지정된 정격 퓨즈만 사용하십시오. 퓨즈가 자주 끊어지면 JVC 자동차 판매점에 문의하십시오.
  - 소음 문제가 있는 경우...  
이 장치의 전원 회로에는 소음 필터가 장착되어 있습니다. 그러나 일부 차량의 경우 딸각이는 소리와 같은 시끄러운 소음이 발생할 수도 있습니다. 이러한 경우 동선이나 게이지 와이어와 같은 짧고 굵은 코드를 사용하여 장치의 뒷면 접지 단자(아래의 연결도 참조)를 자동차의 새시에 연결하십시오. 그래도 계속 소음이 들리면 JVC 자동차 판매점에 문의하십시오.
  - 최대 스피커 입력은 뒤쪽과 앞쪽 모두에서 50W 이상이어야 하고 임피던스는 **4 Ω - 8 Ω** 여야 합니다.
  - 장치는 반드시 자동차 새시에 접지합니다.
  - 사용 후 방열판은 매우 뜨거우므로 장치를 분리할 때 방열판에 닿지 않도록 조심하십시오.

# การเชื่อมต่อใช้ไฟฟ้า

เพื่อป้องกันไฟฟ้าลัดวงจรเราขอแนะนำให้คุณแยกขั้วลบแบตเตอรี่ออกก่อนและทำการเชื่อมต่อใช้ไฟฟ้าทุกจุดก่อนที่จะติดตั้งชุดประกอบลำโพงไม่ว่าจะติดตั้งชุดประกอบนี้ถูกต้องหรือไม่ให้ช่างผู้เชี่ยวชาญเป็นผู้ติดตั้ง

- หมายเหตุ :**  
ชุดประกอบนี้ได้รับการออกแบบมาเพื่อใช้งานกับระบบกระแสไฟฟ้าสายดินขั้วลบระบบแรงดัน **12 โวลท์**
- การรถยนต์ของคุณไม่ได้ใช้ระบบนี้ต้องใช้เครื่องแปลงกระแสไฟฟ้า** ซึ่งสามารถหาซื้อได้จากร้านขายเครื่องเสียงรถยนต์ JVC
- ใช้ฟิวส์เฉพาะเท่านั้น หากฟิวส์ขาดบ่อย ให้ปรึกษาช่างเครื่องเสียงรถยนต์ JVC
  - หากเสียงมีปัญหา...  
ชุดประกอบชุดนี้มีเครื่องกรองเสียงในวงจรกำลัง อย่างไรก็ตามในรถยนต์ บางครั้งก็อาจเกิดเสียงที่ไม่พึงปรารถนาขึ้นได้ หากปัญหานี้เกิดขึ้น ให้ตัดขั้วสายดินด้านหลังของชุดประกอบ (ดูแผนภูมิการเชื่อมต่อด้านหลัง) เข้ากับ เซชชีของรถยนต์โดยใช้สายเคเบิลที่สั้นและหนากว่า เช่น สายไฟเครื่องวัดหรือสายประสานทองแดง เป็นต้น หากยังมีเสียงอยู่ก็ ให้ปรึกษาช่างเครื่องเสียงรถยนต์ JVC
  - ระดับอินพุตที่ติดตั้งชุดของลำโพงควรตั้งเกินกว่า 50 วัตต์ และ 50 วัตต์ ที่ ลำโพงหลังและลำโพงหน้า โดยมีอิมพีแดนซ์ในระดับ **4 Ω - 8 Ω**
  - ตรวจสอบให้แน่ใจว่าได้อุปกรณ์ชุดนี้ลงในเซชชีรถยนต์แล้ว
  - แผ่นระบายความร้อนจะร้อนมากหลังจากใช้ ระดับแรงจูงใจไปยังสัมผัสเมื่อถอดชุดประกอบนี้

## PRECAUTIONS on power supply and speaker connections:

- **DO NOT connect the speaker leads of the power cord to the car battery; otherwise, the unit will be seriously damaged.**
- Connect the black lead (ground), yellow lead (to car battery, constant 12 V), and red lead (to an accessory terminal) correctly.
- BEFORE connecting the speaker leads of the power cord to the speakers, check the speaker wiring in your car.  
- If the speaker wiring in your car is as illustrated in Fig. 1 and Fig. 2 below, DO NOT connect the unit using that original speaker wiring. If you do, the unit will be seriously damaged.  
Redo the speaker wiring so that you can connect the unit to the speakers as illustrated in Fig. 3.
- If the speaker wiring in your car is as illustrated in Fig. 3, you can connect the unit using the original speaker wiring in your car.
- If you are not sure of the speaker wiring of your car, consult your car dealer.

## 電源和揚聲器接線注意事項：

- 切勿把揚聲器導線接頭接至電池，否則本機將會嚴重損壞。
- 正確地連接黑色導線接頭（接地）、黃色導線接頭（接車裝電池，恆定 12V）和紅色導線接頭（接至保險絲單元的附屬端子）。
- 在把揚聲器導線接頭接至揚聲器之前，檢查您汽車上的揚聲器線路：  
- 如果您汽車上揚聲器線路像圖 1 和圖 2 所示，不要使用原裝的揚聲器線路。如果使用，本機將嚴重損壞。  
要重新連接揚聲器線路，可按圖 3 所示，把本機與揚聲器相連接。
- 如果您汽車上揚聲器線路像圖 3 所示，可使用原裝的揚聲器線路與本機相連接。
- 如果您不能確定您汽車上揚聲器線路，請向您的汽車分銷商詢問。

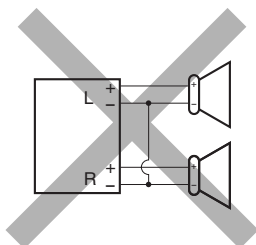

Fig. 1

## 전원 공급장치 및 스피커 연결 시 안전 주의 사항:

- 전원 코드의 스피커 도선을 자동차 배터리에 연결하지 연결하지 마십시오. 장치가 심하게 손상됩니다.
- 검정색 도선 (접지용), 노란색 도선 (자동차 배터리에 연결, 항상 12V) 및 빨간색 도선 (액세서리 단자에 연결)을 올바르게 연결합니다.
- 전원 코드의 스피커 도선을 스피커에 연결하기 전에 자동차의 스피커 배선을 점검합니다.  
- 자동차의 스피커 배선이 아래 그림 1 및 그림 2와 같으면 현재의 스피커 배선을 사용하여 장치를 연결하지 마십시오. 장치가 심하게 손상됩니다.  
그림 3과 같이 스피커에 장치가 연결될 수 있도록 스피커 배선을 다시 합니다.
- 자동차의 스피커 배선이 그림 2와 같으면 자동차에 있는 스피커 배선을 사용하여 장치를 연결할 수 있습니다.
- 자동차의 스피커 배선에 대해 잘 모르면 자동차 판매점에 문의하십시오.

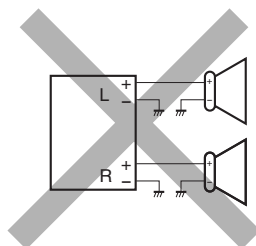

Fig. 2

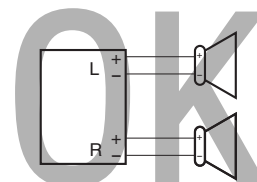

Fig. 3

## About sounds reproduced through the rear terminals

- **Through the analog terminals (Speaker out/LINE OUT/2nd AUDIOOUT):**  
2-channel signal is emitted.  
When playing a multi-channel encoded disc, multi-channel signals are downmixed. (AUDIO—ANALOG DOWN MIX: see page 46 of the Instructions)
- **Through DIGITAL OUT (optical):**  
Digital signals (Linear PCM, Dolby Digital\*, DTS\*\*, MPEG Multichannel) are emitted through this terminal. (For more details, see page 71 of the Instructions.)  
To reproduce multi-channel sounds such as Dolby Digital and DTS, connect an amplifier or a decoder compatible with these multi-channel sources to this terminal, and set "DIGITAL AUDIO OUTPUT" to the correct value. (See page 46 of the Instructions)

\* Manufactured under license from Dolby Laboratories. "Dolby" and the double-D symbol are trademarks of Dolby Laboratories.  
\*\* "DTS" and "DTS Digital Out" are trademarks of Digital Theater Systems, Inc.

## 由背面終端所發出的聲音

- 自模擬端子（揚聲器輸出 /LINE OUT/2nd AUDIO OUT）：  
發出 2 聲道訊號。  
在播放多聲道格式編碼的碟片時，多聲道訊號被進行下行混合。  
(音頻—模擬下行混合)：參使用說明書的闕第 46 頁)
- 自 DIGITAL OUT (光學端子)：  
自此端子發出數碼訊號 (線性 PCM, 杜比數碼\*, DTS\*\*, MPEG Multichannel) (參使用說明書的闕第 71 頁。)  
若要再生多聲道聲音，如杜比數碼和 DTS 時，可將與這些多聲道播放源兼容的解碼器或擴音器連接至此端子，並將“數碼音頻輸出”設定在正確值。(參使用說明書的闕第 46 頁)

\* 經杜比實驗室授權生產。“杜比”，“Dolby”和雙 D 標誌是杜比實驗室的商標。  
\*\* “DTS”和“DTS Digital Out”是數碼影院音響公司之商標。

## 리어 단자에서 재현되는 사운드에 대하여

- **아날로그 터미널(스피커 출력/LINE OUT (라인 출력)/2nd AUDIO OUT(두번째 오디오 출력)):**  
2-채널 신호가 출력됩니다.  
암호화된 다중 채널 디스크를 재생할 때는 다중 채널 신호가 다운믹스됩니다.  
(AUDIO—ANALOG DOWN MIX: 46 페이지의 설명 참조)
- **DIGITAL OUT 을 통해(광학):**  
디지털 신호(선형 PCM, 돌비 디지털\*, DTS\*\* MPEG Multichannel)가 이 터미널을 통해 출력됩니다. (자세한 사항은 71 페이지의 설명 참조.)  
돌비 디지털, DTS 등과 같은 다중 채널 사운드를 재생하려면 이러한 다중 채널 소스와 호환되는 디코더나 앰프를 이 터미널에 연결하고 "DIGITAL AUDIO OUTPUT(디지털 오디오 출력)"을 올바른 값으로 설정하십시오.  
(46 페이지의 설명 참조)

\* Dolby Laboratories의 사용 승인을 받아 제조됨.  
"Dolby" 이중 D 기호는 Dolby Laboratories의 상표입니다.  
\*\* "DTS"와 "DTS Digital Out"은 Digital Theater Systems, Inc.의 상표입니다.

## เกี่ยวกับเสียงที่สร้างขึ้นใหม่ผ่านขั้วต่อด้านหลัง

- **ผ่านขั้วต่อแบบอนาล็อก (Speaker out/LINE OUT/2nd AUDIO OUT):**  
สัญญาณแบบ 2 แชนแนลจะถูกส่งออกมา  
เมื่อเล่นแผ่นที่เข้ารหัส multi-channel สัญญาณ multi-channel จะผสมเข้ามา (AUDIO—ANALOG DOWN MIX: โปรดดูหน้า 46)
- **ผ่านขั้วต่อ DIGITAL OUT (optical):**  
สัญญาณดิจิทัล (Linear PCM Dolby Digital\* DTS\*\* MPEG multi-channel) จะถูกส่ง ออกมาผ่าน ขั้วนี้ (ดูรายละเอียดเพิ่มเติมในหน้า 71)  
วิธีสร้างเสียงแบบ multi-channel ขึ้นมาใหม่ เช่น Dolby Digital และ DTS ให้ต่อแอมป์ไฟเออร์หรือเครื่องถอดรหัส (decoder) ที่สามารถใช้กับแหล่งกำเนิดเสียงแบบ multi-channel ได้ ขั้วทางขั้วนี้ แล้วตั้ง "DIGITAL AUDIO OUTPUT" ให้มีค่าถูกต้อง (โปรดดูหน้า 46)

\* ผลิตภัณฑ์ใบอนุญาตจาก Dolby Laboratories สัญญลักษณ์ "Dolby" และตัวอักษร D สองตัวเป็นเครื่องหมายการค้าของ Dolby Laboratories  
\*\* "DTS" และ "DTS Digital Out" เป็นเครื่องหมายการค้าของ Digital Theater Systems, Inc.

## A Typical Connections / 典型的接線方法 / 일반적인 연결 / การเชื่อมต่อแบบปกติ

**Before connecting:** Check the wiring in the vehicle carefully not to fail in connecting this unit. Incorrect connection may cause a serious damage to this unit.

The leads of the power cord and those of the connector from the car body may be different in color.

**1** Connect the colored leads of the power cord to the car battery, speakers and automatic antenna (if any) in the following sequence.

- ① Black: ground
- ② Yellow: to car battery (constant 12 V)
- ③ Red: to an accessory terminal
- ④ Blue: to automatic antenna if any (250 mA max.)
- ⑤ Blue with white stripe: to remote lead of other equipment (200 mA max.)
- ⑥ Light green: To parking brake, metallic body or chassis of the car
- ⑦ Orange with white stripe: to car light control switch
- ⑧ Brown: To cellular phone system (For details, refer to the instructions of the cellular phone.)
- ⑨ Others: to speakers

**2** Connect the antenna cord.

**3** Finally connect the wiring harness to the unit.

接線前: 仔細檢查汽車內的線路。不正確的接線會導致本機嚴重損壞。

電力線的引線和車身的連接器引線在顏色上可能有所不同。

**1** 按下述順序將配線束各個不同色標的導線接頭分別接至電池、揚聲器和自動電源升降天線 (如有裝設):

- ① 黑色: 接地
- ② 黃色: 接至車裝電池 (恆定 12V)
- ③ 紅色: 接至附屬端子
- ④ 藍色: 接至自動升降天線, 若有裝設 (最大 250 mA)
- ⑤ 藍色帶有白色條紋: 和其他裝置上的遙控線連接起來。(最大 200 mA)
- ⑥ 淺青色: 接至停車制動器、金屬車身或車殼。
- ⑦ 橙色帶有白色條紋: 接至汽車燈光控制轉換器
- ⑧ 褐色: 接至流動電話系統 (詳情請參閱流動電話手冊)
- ⑨ 其他: 接至揚聲器

**2** 將天線的電線連接起來。

**3** 最後, 把配線束的插頭插在本機上。

연결하기 전에: 차량 배선을 주의해서 점검하십시오. 잘못 연결하면 장치가 심하게 손상될 수 있습니다.

전원 코드의 도선과 자동차 본체에 부착된 커넥터의 도선 색상이 서로 다를 수 있습니다.

**1** 색으로 구분된 전원 코드의 도선을 다음과 같은 순서로 자동차 배터리, 스피커 및 자동 안테나(장착된 경우)에 연결합니다.

- ① 검정색: 접지용
- ② 노란색: 자동차 배터리에 연결 (항상 12V)
- ③ 빨간색: 액세서리 단자에 연결
- ④ 파란색: 자동 안테나가 있는 경우 여기에 연결됨 (최대 250 mA)
- ⑤ 흰색 줄무늬가 있는 파란색 도선: 외부 기기의 원격도선에 연결됨 (최대 200 mA)
- ⑥ 연한 녹색: 주차 브레이크, 자동차의 금속 본체 또는 새시에 연결
- ⑦ 흰색 줄무늬가 있는 오렌지색: 자동차 조명 제어 스위치에 연결
- ⑧ 갈색: 휴대폰에 연결 (자세한 내용은 휴대폰 설명서 참조)
- ⑨ 기타: 스피커에 연결

**2** 안테나 코드에 연결합니다.

**3** 마지막으로 배선을 장치에 연결합니다.

ก่อนทำการเชื่อมต่อ: ตรวจสอบการเดินสายไฟในรถอย่างระมัดระวังเพื่อหลีกเลี่ยงความเสียหายร้ายแรงต่อชุดประกอบชุดที่ภาคต่อที่ผิดพลาดอาจทำให้เกิดความเสียหายร้ายแรงกับชุดประกอบชุดที่ภาคต่อได้ วัตถุประสงค์ของสายไฟ และของอุปกรณ์ต่อเชื่อมจากตัวรถคลออาจมีที่ในแบบคลอถัด

**1** ต่อสายต่อสีของสายไฟเข้ากับแบตเตอรี่รถยนต์ ลำโพง และเสาอากาศพาเวอร์อัตโนมัติ (ถ้ามี) ตามลำดับต่อไปนี้

- ① สีดำ: สายดิน
- ② สีเหลือง: ต่อกับแบตเตอรี่รถยนต์ (12 โวลท์คงที่)
- ③ สีแดง: ต่อกับขั้วส่วนประกอบ
- ④ สีฟ้า: เสาอากาศไฟฟ้อัตโนมัติ หากมี (ขนาดสูงสุด 250 mA)
- ⑤ สายสีฟ้าที่มีแถบขาว: ต่อกับสายตะกั่วระยะไกลของอุปกรณ์อื่น (ขนาดสูงสุด 200 mA)
- ⑥ สีเขียวอ่อน: ต่อกับเบรคมือ ตัวถังที่เป็นโลหะ หรือโครงรถยนต์
- ⑦ สีส้มแถบขาว: ต่อกับสวิตซ์ควบคุมไฟของรถยนต์
- ⑧ สีน้ำตาล: ต่อกับโทรศัพท์เคลื่อนที่ (อ่านรายละเอียดได้จากคู่มือที่มาพร้อมกับโทรศัพท์เคลื่อนที่)
- ⑨ สีอื่น ๆ: ต่อกับลำโพง

**2** เชื่อมต่อกับสายอากาศ

**3** สุดท้าย ต่อส่วนควบคุมการเดินสายไฟเข้ากับชุดประกอบชุดนี้

Before connecting the CD changer, make sure that the unit is turned off.

連接 CD 轉換器之前, 應先將本機關閉。

교환기를 연결하기 전에 장치 전원을 끄십시오.

ก่อนจะเชื่อมต่อเครื่องเล่นซีดี กรุณาตรวจสอบให้แน่ใจว่าเครื่องเล่นซีดีนั้นปิด

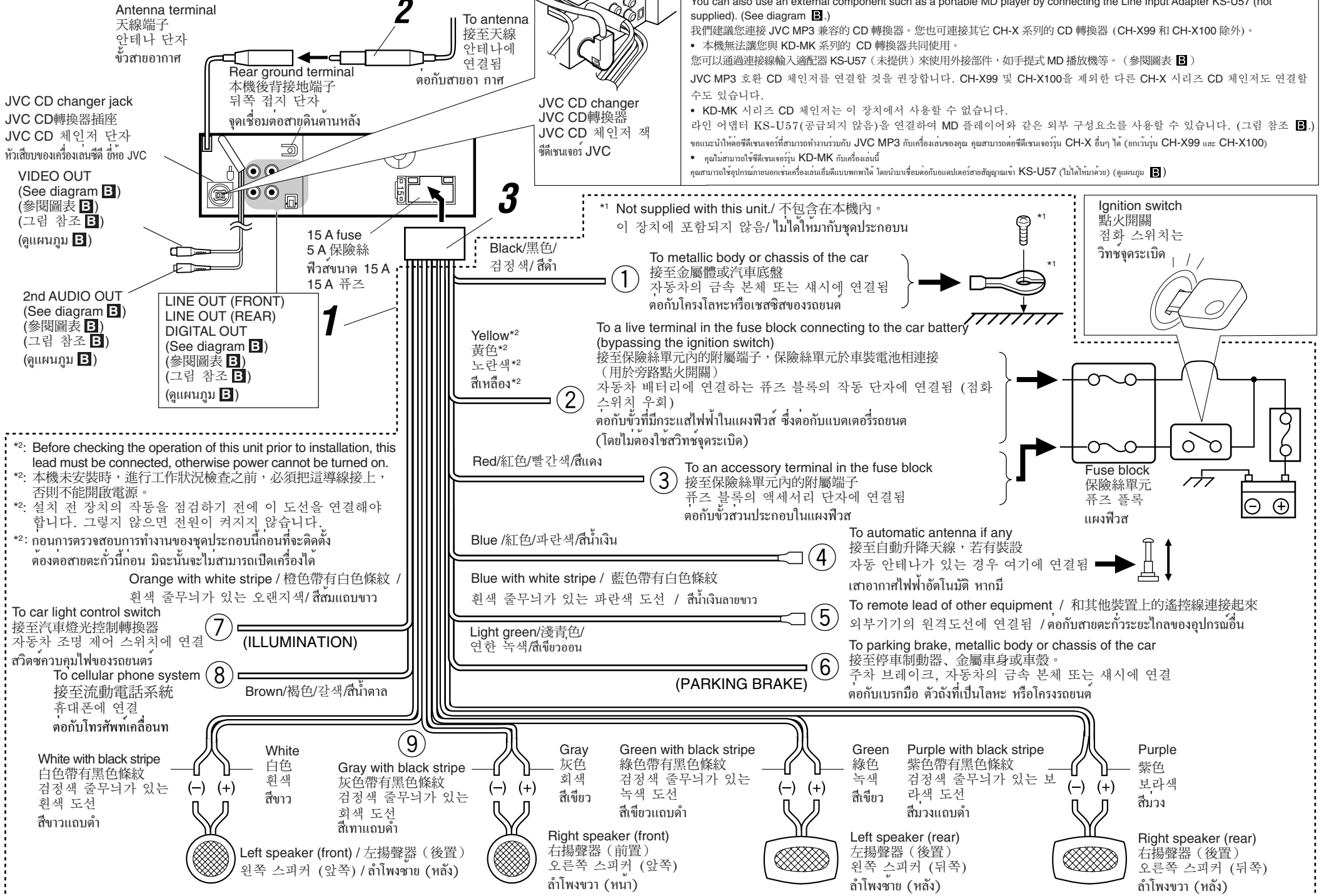

## Connecting the parking brake wire / 連接停車制動器 / 주차 브레이크 도선 연결 / ต่อสายเบรคมือ

When installing the monitor in a location where it can be seen by the driver

若屏幕被安裝在一個司機可以看見的地方

드라이버가 볼 수 있는 장소에 모니터를 설치하는 경우

เมื่อจะติดตั้งจอมอนิเตอร์ในตำแหน่งที่ผู้ขับขี่สามารถมองเห็นได้

Connect the parking brake wire to the parking brake system built in the car.

將停車制動器的電線連接至內置在車上的停車制動系統。

주차 브레이크 도선을 자동차에 내장된 주차 브레이크 시스템에 연결합니다.

ต่อสายเบรคมือกับระบบเบรคมือของรถยนต์

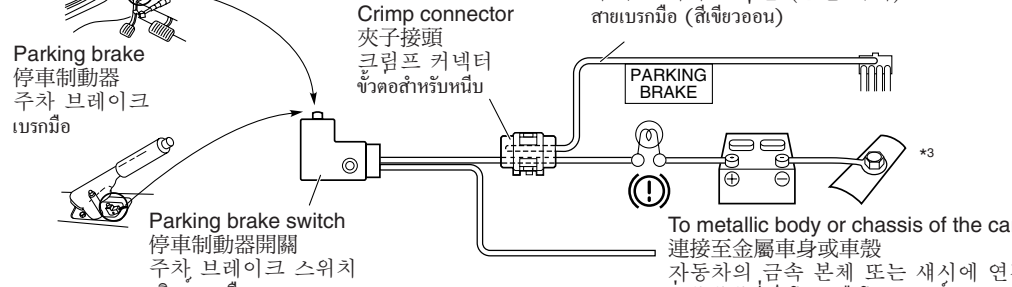

## When installing the monitor in a location where it cannot be seen by the driver

若屏幕被安裝在一個司機看不見的地方

드라이버가 볼 수 없는 장소에 모니터를 설치하는 경우

เมื่อจะติดตั้งจอมอนิเตอร์ในตำแหน่งที่ผู้ขับขี่ไม่สามารถมองเห็นได้

Connect the parking brake wire to metallic body or chassis of the car.

將停車制動電線連接至金屬車身或車殼。

주차 브레이크 도선을 자동차의 금속 본체 또는 새시에 연결합니다.

ต่อสายเบรคมือกับตัวถังที่เป็นโลหะหรือโครงรถยนต์

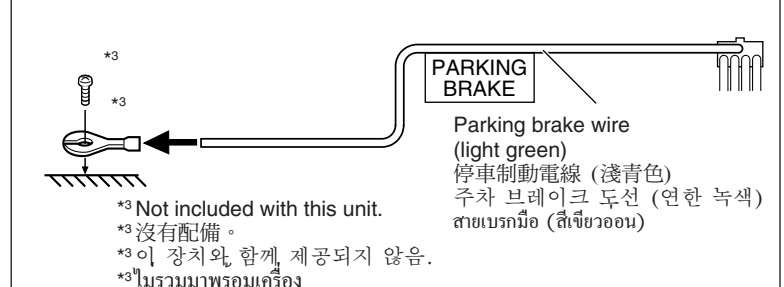

**How to connect the crimp connector / 如何連接至夾子接頭 / 크립 커넥터 연결 / วิธีต่อหัวต่อสำหรับหมัม**

Wire connecting the battery and the parking brake switch  
 連接電池和停車制動器開關的電線  
 배터리와 주차 브레이크 스위치를 연결하는 도선  
 สายที่ต่อกับแบตเตอรี่และสวิตช์เบรคมือ

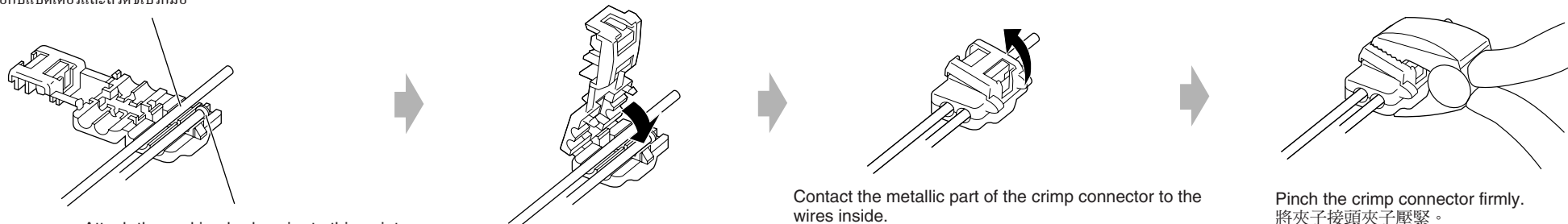

Attach the parking brake wire to this point.  
 將停車制動器電線連接至這點。  
 주차 브레이크 도선을 이 포인트에 장착합니다.  
 此สายเบรคมือที่จุดนี้

Contact the metallic part of the crimp connector to the wires inside.  
 將夾子接頭的金屬部份連接至裡面的電線。  
 크립프의 금속부위가 내부의 도선에 접촉하도록 합니다.  
 此ส่วนที่เป็นโลหะของตัวหมัมสัมผัสกับสายข้างใน

Pinch the crimp connector firmly.  
 將夾子接頭夾子壓緊。  
 크립프를 단단히 조여 주십시오.  
 หมัมนี้แน่น

**B Connections Adding Other Equipment / 連接附加的其他音響設備 / 기타 추가 장비 연결 / การต่อเพิ่มเติมเข้ากับอุปกรณ์อื่น**

You can connect an amplifier and other equipment to upgrade your car stereo system.

- Connect the remote lead (blue with white stripe) to the remote lead of the other equipment so that it can be controlled through this unit.
- For amplifier:
  - Connect this unit's line-out terminals to the amplifier's line-in terminals.
  - **Disconnect the speakers from this unit, connect them to the amplifier. Leave the speaker leads of this unit unused.**

你可以連接放大器和其裝置以加強你的汽車音響系統功能。

- 將遙控線 (藍色帶有白色條紋) 和其他裝置上的遙控線連接起來，以便可以通過本機進行遙控。
- 僅適用於放大器：
  - 將本機的輸出終端和放大器輸入終端連接起來。
  - 將揚聲器和本機斷開，再連接上放大器。將本機的揚聲器接線放置不用。

증폭기 및 기타 장비를 연결하여 자동차 스테레오 시스템을 업그레이드할 수 있습니다.

- 장비가 장치를 통해 제어될 수 있도록 나머지 장비의 원격 도선에 장치의 원격 도선 (흰색 줄무늬가 있는 파란색 도선)을 연결합니다.
- 증폭기의 경우:
  - 장치의 출력 단자를 앰프의 입력 단자에 연결합니다.
  - 스피커를 이 장치에서 분리한 다음 앰프에 연결합니다. 장치의 스피커 도선은 사용하지 않은 상태로 둡니다.

คุณสามารถต่อเครื่องขยายและอุปกรณ์อื่น ๆ เพื่ออัพเกรดระบบเครื่องเสียงในรถยนต์ของคุณได้

- ต่อสายตัวกระชาก (สีน้ำเงินลายขาว) เข้ากับสายตัวกระชากไกลของอุปกรณ์อื่น ๆ เพื่อสามารถควบคุมโดยชุดประกอบนี้ได้
- สำหรับเครื่องขยายเท่านั้น:
  - ต่อขั้วสายออก ของชุดประกอบนี้เข้ากับขั้วสายเข้าของเครื่องขยาย
  - **ถอดลำโพงออกจากชุดประกอบนี้ แล้วต่อเข้ากับเครื่องขยายที่สายตัวกระชากไกลของชุดประกอบนี้ไว้**

**Required connections for DVD playback / DVD 部份所需的連接 / DVD 재생에 필요한 연결 / จำเป็นต้องต่อสำหรับการเล่น DVD**

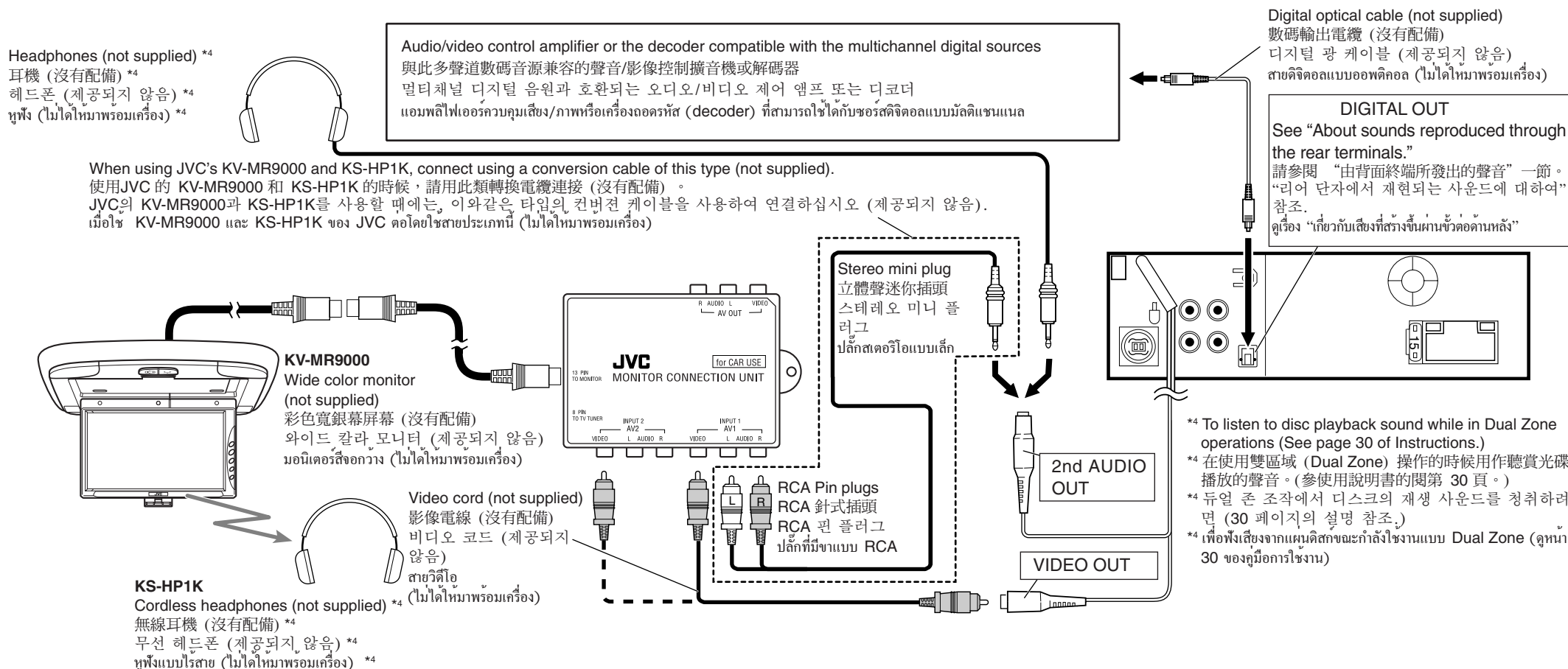

**Amplifier / 功率放大器 / 증폭기 / เครื่องขยาย**

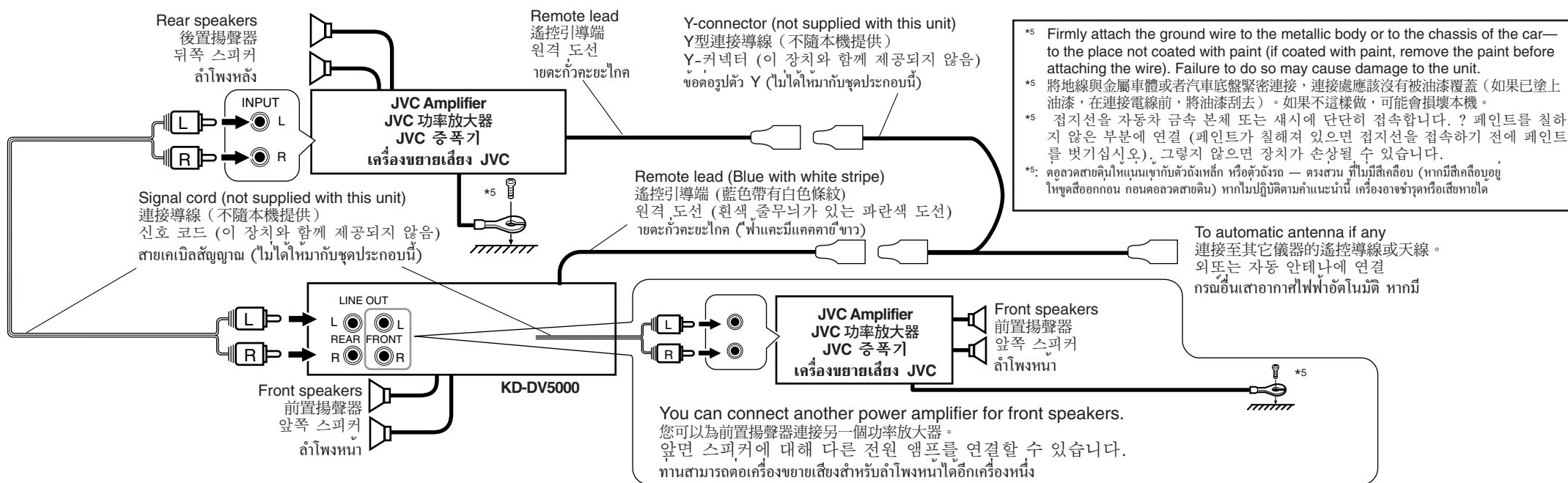

**External component / 外接部件 / 서브유퍼 / อุปกรณ์ภายนอก**

